

# Premium Linear Actuator



Premium Linear Actuators are compact and versatile to suit the needs of a variety of automation projects. They are IP66 rated and manufactured with enhanced corrosion resistance to provide maximum life and value. Standard strokes up to 30 inches and forces up to 200 lbs are available as well as custom strokes and forces.

## Standard Features and Benefits

- **Internal limit switches** automatically shut off the unit at the end of stroke
- **Standard stroke lengths** of 1, 2, 3, 4, 6, 9, 12, 18, 24 and 30 inches are available
- **200 lbs. of force** at an extension speed of .24 inches per second, **150 lbs. of force** at .3 inches per second, and **35 lbs. of force** at 2 inches per second
- **IP 66 rated** - dust proof and water resistant
- **Temperature operating range** of -15°F to 150°F ( -26°C to 65°C)
- **High grade aluminum housing** resists corrosion
- **Custom strokes, speeds, or forces** available upon request
- **Maintenance free**
- **CE and RoHS certified**

## Specifications

Model	FA-35-12-(X)-(P)	FA-150-12-(X)-(P)	FA-240-12-(X)-(P)
Dynamic Force	35 lb	150 lb	200 lb
Static Force	200 lb	500 lb	500 lb
Speed (inches/second)	2 inches	0.30 inches	0.24 inches
Duty Cycle	25%		
Stroke Length	1, 2, 3, 4, 6, 9, 12, 18, 24 and 30 inches		
IP Rating	66		
Input	12 volt DC		
Max Draw	5 A		
Clevis End	1/4" diameter		
Operational Temperature	-15°F to 150°F (-26°C to 65°C)		
Limit Switch	Built-in (factory preset)		
Safety Certifications	CE, RoHS		
Brackets	MB1-P		

## Dimensions and Weight

Stroke	Retracted Length	Extended Length	Weight
1 "	5.53 "	6.53 "	1.60 lbs
2 "	6.53 "	8.53 "	1.68 lbs
3 "	7.53 "	10.53 "	1.84 lbs
4 "	8.53 "	12.53 "	1.92 lbs
6 "	10.53 "	16.53 "	2.12 lbs
9 "	13.53 "	22.53 "	2.48 lbs
12 "	16.53 "	28.53 "	2.78 lbs
18 "	22.53 "	40.53 "	3.40 lbs
24 "	28.53 "	52.53 "	4.02 lbs
30 "	34.53 "	64.53 "	4.68 lbs

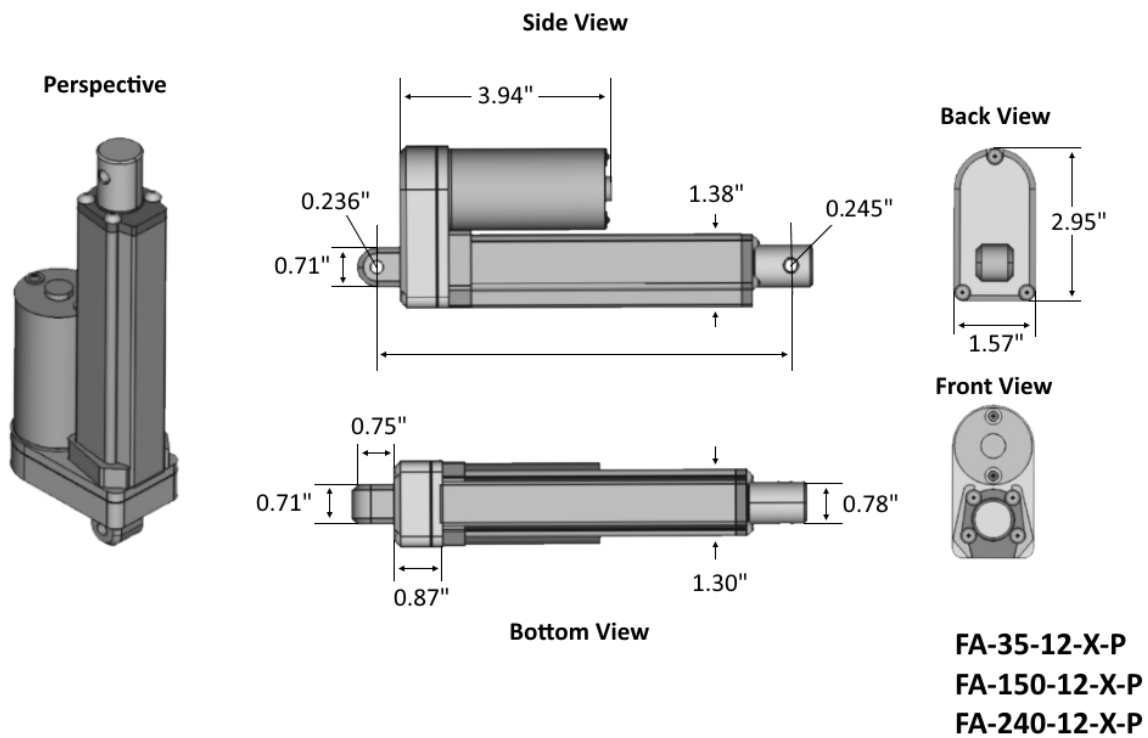

## Performance Graphs

