

FLOW MICRO-REGULATOR

The job of flow microregulators is to regulate speed in the pneumatic cylinders. The configuration of both type C (to be mounted on the cylinder inlet) and type V (to be mounted on the valve port) is such as to ensure full flow on feed and regulated flow on discharge. Type B (bidirectional) can be used to regulate the flow both on feed and discharge. Flow microregulators have reduced dimensions and fine adjustment in the first turns; they can be adjusted using the knob and/or screwdriver; adjustment can be prevented by tightening the ring nut.

Main features:

- reduced dimensions
- excellent regulation
- regulation with either a screwdriver and/or a knob, can be fixed with a ring nut (COMPACT N)
- available in all sizes (from 10-32 UNF to 1/2" NPT) with a brass ring
- can be mounted with an automatic screwdriver
- comes with a ring that can rotate even with the MRF mounted in position.



TECHNICAL DATA	10-32 UNF			1/8" NPT			1/4" NPT			3/8" NPT		1/2" NPT		
	Ø 5/32	Ø 1/4	Ø 5/32	Ø 1/4	Ø 5/16	Ø 3/8	Ø 1/4	Ø 5/16	Ø 3/8	Ø 1/2	Ø 3/8	Ø 1/2	Ø 1/2	
Pipe														
Max input pressure	MPa													
	bar													
	psi													
Temperature range: Brass ring	°C													
	°F													
Max flow rate in regulation at 90 psi	Nl/min	150	155	350	380	400	400	750	850	950	1000	1300	1400	2000
Max flow rate full port at 90 psi with closed needle	Nl/min	140	150	300	350	390	390	450	500	500	550	1050	1250	1750
Max flow rate full port at 90 psi with open needle	Nl/min	240	245	450	600	650	650	850	1050	1150	1250	1700	2100	2700
Regulation	Manual or using a screwdriver													
Internal system	Tapered needle													
Fluid	Filtered, lubricated or unlubricated compressed air													

FLOW MICRO-REGULATOR

ACCESSORIES

TYPE N COMPONENTS - 10-32 UNF THREAD

- ① Nickel-plated brass knob
- ② Nickel-plated brass securing ring nut
- ③ Brass needle
- ④ Nickel-plated brass bush
- ⑤ Nickel-plated brass body
- ⑥ Nickel-plated brass retaining ring
- ⑦ NBR gasket
- ⑧ Nickel-plated brass revolving ring
- ⑨ NBR gasket
- ⑩ Technopolymer spring supporting ring
- ⑪ Stainless steel grabbing spring
- ⑫ Technopolymer retaining bush
- ⑬ Technopolymer release bush

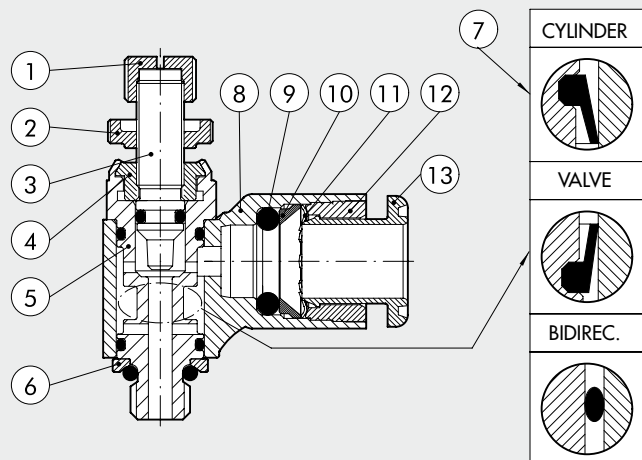

TYPE N COMPONENTS - THREAD 1/8" TO 1/2"

- ① Nickel-plated brass knob
- ② Nickel-plated brass securing ring nut
- ③ Brass needle
- ④ Nickel-plated brass body
- ⑤ Nickel-plated brass retaining ring
- ⑥ Brass gasket holding insert
- ⑦ NBR gasket
- ⑧ Nickel-plated brass revolving ring
- ⑨ NBR gasket
- ⑩ Technopolymer spring supporting ring
- ⑪ Stainless steel grabbing spring
- ⑫ Technopolymer retaining bush
- ⑬ Technopolymer release bush

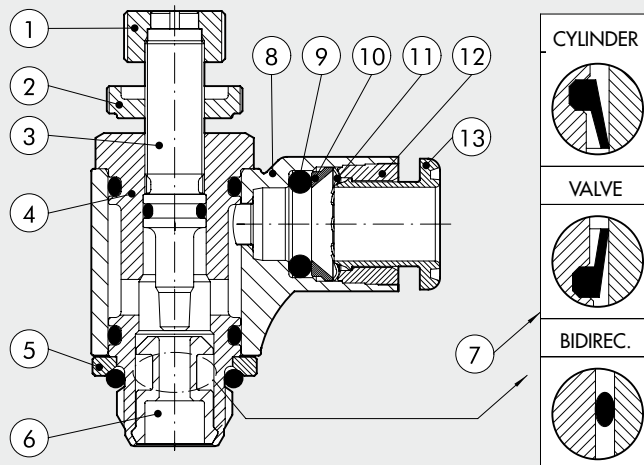

All the MRF with a pipe engage-release system of the latest generation that facilitates detachment of the pipe even under difficult operating conditions.

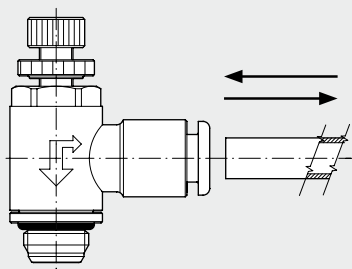

The rings can be rotated even with the MRF installed, which means that they can be mounted with the pipe facing towards any direction.

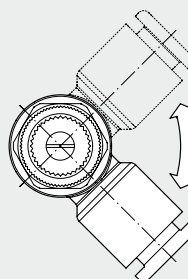

All the new MRF can be fixed from the top using a universal wrench, a pipe wrench or an automatic screwdriver.

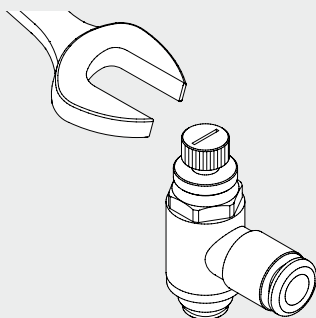

FLOW CHARTS

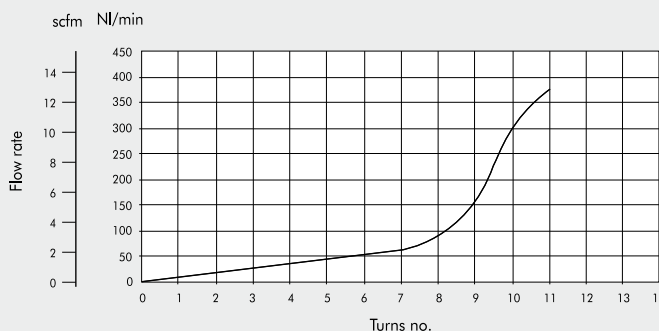

Thread	MAX. TORQUE (lb f ft)*
10/32	1.33
1/8" NPT	4.33
1/4" NPT	5.90
3/8" NPT	7.38
1/2" NPT	11.06

* measured on a metal female thread

The regulation curve in the MRF COMPACT N, takes place in two sections: in the first half of the flash pin stroke for very fine regulation and relatively low flow rates; in the second half, the flash pin quickly opens the passage so as to reach the maximum flow rate quickly.

FLOW CHARTS

MRF 10-32 UNF - PIPE Ø5-32 - Ø1/4

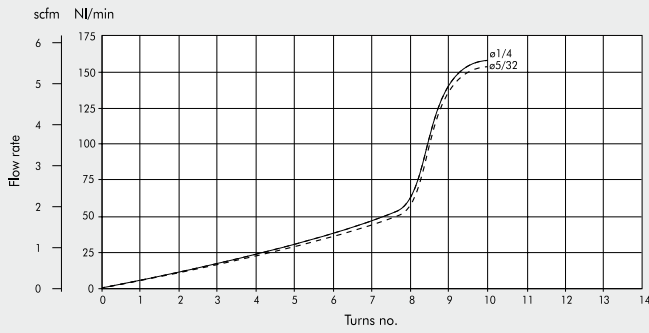

MRF 1/8" NPT - PIPE Ø5/32 - Ø1/4 - Ø5/16 - Ø3/8

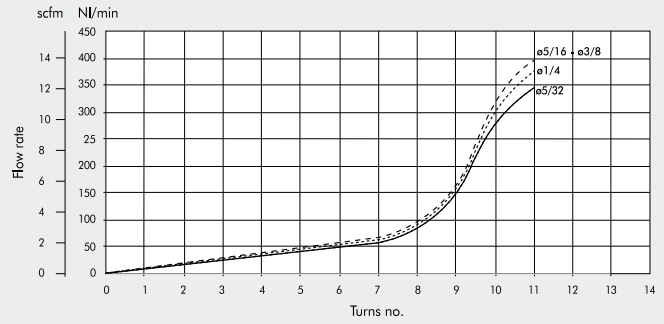

MRF 1/4" NPT - PIPE Ø1/4 - Ø5/16 - Ø3/8 - Ø1/2

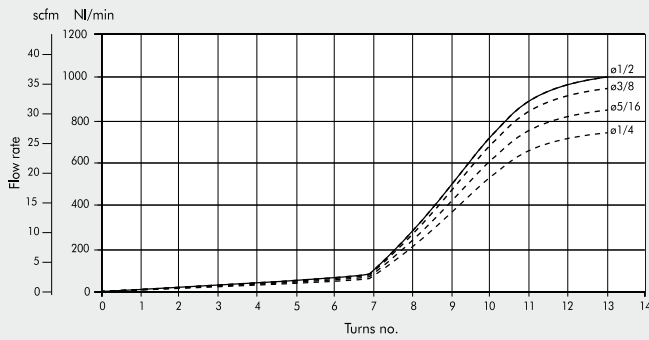

MRF 3/8" NPT - PIPE Ø3/8 - Ø1/2

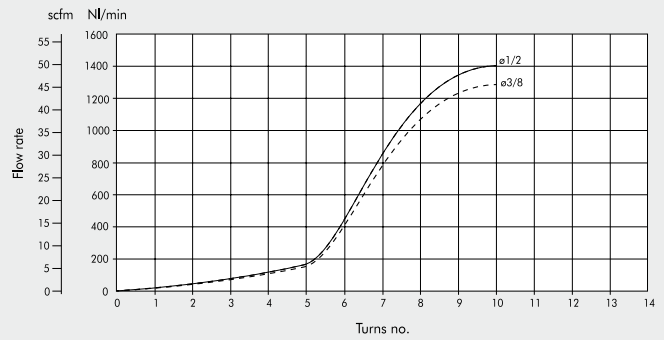

MRF 1/2" NPT - PIPE Ø1/2

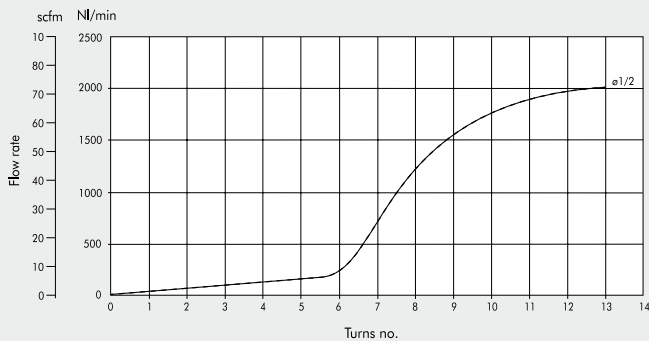

KEY TO CODES

M R F FAMILY	N TYPE	M RING	C FUNCTION	1/4 Ø PIPE	1/8 NPT THREAD
Flow micro-regulator	N With knob and ring nut	M Nickel-plated brass with push-in fitting	C For cylinder V For valve B Bidirectional	5/32 Ø 5/32 1/4 Ø 1/4 5/16 Ø 5/16 3/8 Ø 3/8 1/2 Ø 1/2	10-32 UNF 10-32 UNF 1/8 NPT 1/8" NPT 1/4 NPT 1/4" NPT 3/8 NPT 3/8" NPT 1/2 NPT 1/2" NPT

MRF COMPACT "N" BRASS RING

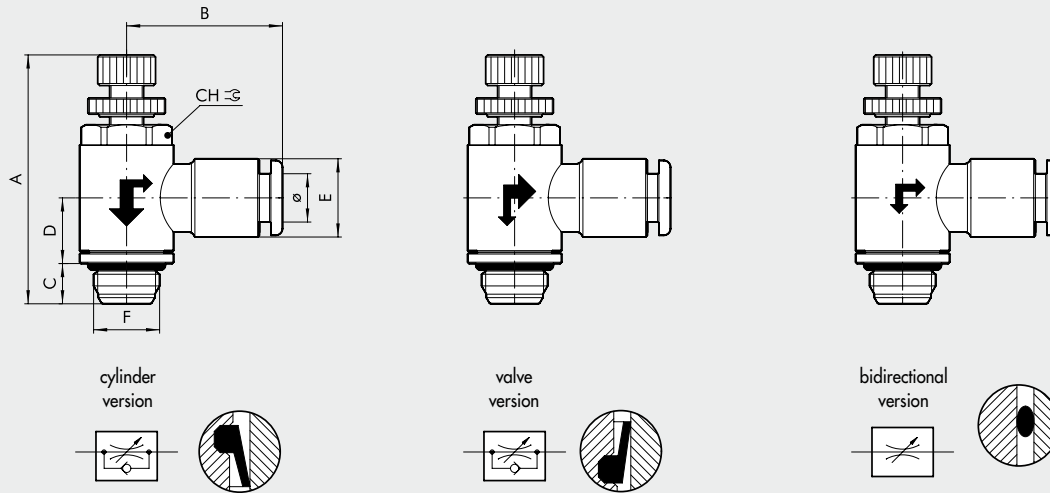

Code	Description	F	Ø	Ch		A min	A max	B	C	D	E
				Inc	mm						
9U31001C	MRF N M C 5/32 10/32 UNF	10/32" UNF	5/32"	0.354	9	1.091	1.220	0.795	0.157	0.362	0.374
9U31101V	MRF N M V 5/32 10/32 UNF	10/32" UNF	5/32"	0.354	9	1.091	1.220	0.795	0.157	0.362	0.374
9U31201B	MRF N M B 5/32 10/32 UNF	10/32" UNF	5/32"	0.354	9	1.091	1.220	0.795	0.157	0.362	0.374
9U31005C	MRF N M C 1/4 10/32 UNF	10/32" UNF	1/4"	0.354	9	1.091	1.220	0.839	0.157	0.362	0.465
9U31105V	MRF N M V 1/4 10/32 UNF	10/32" UNF	1/4"	0.354	9	1.091	1.220	0.839	0.157	0.362	0.465
9U31205B	MRF N M B 1/4 10/32 UNF	10/32" UNF	1/4"	0.354	9	1.091	1.220	0.839	0.157	0.362	0.465
9U31002C	MRF N M C 5/32 1/8 NPT	1/8" NPT	5/32"	0.472	12	1.319	1.480	0.839	0.236	0.386	0.374
9U31102V	MRF N M V 5/32 1/8 NPT	1/8" NPT	5/32"	0.472	12	1.319	1.480	0.839	0.236	0.386	0.374
9U31202B	MRF N M B 5/32 1/8 NPT	1/8" NPT	5/32"	0.472	12	1.319	1.480	0.839	0.236	0.386	0.374
9U31006C	MRF N M C 1/4 1/8 NPT	1/8" NPT	1/4"	0.472	12	1.319	1.480	0.839	0.236	0.386	0.465
9U31106V	MRF N M V 1/4 1/8 NPT	1/8" NPT	1/4"	0.472	12	1.319	1.480	0.839	0.236	0.386	0.465
9U31206B	MRF N M B 1/4 1/8 NPT	1/8" NPT	1/4"	0.472	12	1.319	1.480	0.839	0.236	0.386	0.465
9U31008C	MRF N M C 5/16 1/8 NPT	1/8" NPT	5/16"	0.472	12	1.319	1.480	0.976	0.236	0.386	0.543
9U31108V	MRF N M V 5/16 1/8 NPT	1/8" NPT	5/16"	0.472	12	1.319	1.480	0.976	0.236	0.386	0.543
9U31208B	MRF N M B 5/16 1/8 NPT	1/8" NPT	5/16"	0.472	12	1.319	1.480	0.976	0.236	0.386	0.543
9U31010C	MRF N M C 3/8 1/8 NPT	1/8" NPT	3/8"	0.472	12	1.319	1.480	1.094	0.236	0.386	0.650
9U31110V	MRF N M V 3/8 1/8 NPT	1/8" NPT	3/8"	0.472	12	1.319	1.480	1.094	0.236	0.386	0.650
9U31210B	MRF N M B 3/8 1/8 NPT	1/8" NPT	3/8"	0.472	12	1.319	1.480	1.094	0.236	0.386	0.650
9U31007C	MRF N M C 1/4 1/4 NPT	1/4" NPT	1/4"	0.591	15	1.528	1.720	0.906	0.315	0.437	0.465
9U31107V	MRF N M V 1/4 1/4 NPT	1/4" NPT	1/4"	0.591	15	1.528	1.720	0.906	0.315	0.437	0.465
9U31207B	MRF N M B 1/4 1/4 NPT	1/4" NPT	1/4"	0.591	15	1.528	1.720	0.906	0.315	0.437	0.465
9U31009C	MRF N M C 5/16 1/4 NPT	1/4" NPT	5/16"	0.591	15	1.528	1.720	1.043	0.315	0.437	0.543
9U31109V	MRF N M V 5/16 1/4 NPT	1/4" NPT	5/16"	0.591	15	1.528	1.720	1.043	0.315	0.437	0.543
9U31209B	MRF N M B 5/16 1/4 NPT	1/4" NPT	5/16"	0.591	15	1.528	1.720	1.043	0.315	0.437	0.543
9U31011C	MRF N M C 3/8 1/4 NPT	1/4" NPT	3/8"	0.591	15	1.528	1.720	1.173	0.315	0.437	0.650
9U31111V	MRF N M V 3/8 1/4 NPT	1/4" NPT	3/8"	0.591	15	1.528	1.720	1.173	0.315	0.437	0.650
9U31211B	MRF N M B 3/8 1/4 NPT	1/4" NPT	3/8"	0.591	15	1.528	1.720	1.173	0.315	0.437	0.650
9U31014C	MRF N M C 1/2 1/4 NPT	1/4" NPT	1/2"	0.591	15	1.528	1.720	1.350	0.315	0.437	0.827
9U31114V	MRF N M V 1/2 1/4 NPT	1/4" NPT	1/2"	0.591	15	1.528	1.720	1.350	0.315	0.437	0.827
9U31214B	MRF N M B 1/2 1/4 NPT	1/4" NPT	1/2"	0.591	15	1.528	1.720	1.350	0.315	0.437	0.827
9U31012C	MRF N M C 3/8 3/8 NPT	3/8" NPT	3/8"	3/4	19	1.858	2.047	1.205	0.354	0.528	0.630
9U31112V	MRF N M V 3/8 3/8 NPT	3/8" NPT	3/8"	3/4	19	1.858	2.047	1.205	0.354	0.528	0.630
9U31212B	MRF N M B 3/8 3/8 NPT	3/8" NPT	3/8"	3/4	19	1.858	2.047	1.205	0.354	0.528	0.630
9U31015C	MRF N M C 1/2 3/8 NPT	3/8" NPT	1/2"	3/4	19	1.858	2.047	1.437	0.354	0.528	0.795
9U31115V	MRF N M V 1/2 3/8 NPT	3/8" NPT	1/2"	3/4	19	1.858	2.047	1.437	0.354	0.528	0.795
9U31215B	MRF N M B 1/2 3/8 NPT	3/8" NPT	1/2"	3/4	19	1.858	2.047	1.437	0.354	0.528	0.795
9U31016C	MRF N M C 1/2 1/2 NPT	1/2" NPT	1/2"	7/8	22	2.087	2.354	1.496	0.433	0.626	0.795
9U31116V	MRF N M V 1/2 1/2 NPT	1/2" NPT	1/2"	7/8	22	2.087	2.354	1.496	0.433	0.626	0.795
9U31216B	MRF N M B 1/2 1/2 NPT	1/2" NPT	1/2"	7/8	22	2.087	2.354	1.496	0.433	0.626	0.795