

Mini Linear Actuator



Standard Features and Benefits

- **Internal limit switches** automatically shut off the unit at the end of stroke
- **Standard stroke lengths** of 2, 4, 6, 8, 10, and 12 inches are available
- **15 lbs. of force** at an extension speed of 1 inch per second
- **IP 54 rated** - dust protected and splash proof
- **Temperature operating range** of -15°F to 150°F (-26°C to 65°C)
- **High grade aluminum housing** resists corrosion
- **Maintenance free**
- **CE and RoHS certified**

The Mini Linear Actuator was designed for small spaces with a small overall footprint and a very light weight. Available in strokes from 2-12 inches and with 15 lbs of force, it is ideal for home and automotive automation projects. Manufactured with high grade aluminum and quality internals, the Mini Linear Actuator provides reliable, trouble free operation.

Specifications

| | |
|--------------------------------|--------------------------------|
| Model | FA-RMS-15-12-X |
| Dynamic Force | 15 lb |
| Static Force | 30 lb |
| Speed (inches/second) | 1 inch |
| Duty Cycle | 25% at 100%, 50% at 25% load |
| Stroke Length | 2, 4, 6, 8, 10, and 12 inches |
| IP Rating | 54 |
| Input | 12 volt DC |
| Max Draw | 2.5 A |
| Clevis End | 1/4" diameter |
| Operational Temperature | -15°F to 150°F (-26°C to 65°C) |
| Limit Switch | Built-in (factory preset) |
| Safety Certifications | CE, RoHS |
| Brackets | MB1 |

Dimensions and Weight

| Stroke | Retracted Length | Extended Length | Weight |
|--------|------------------|-----------------|---------|
| 2 " | 9.25 " | 11.25 " | 1.1 lbs |
| 4 " | 11.25 " | 15.25 " | 1.3 lbs |
| 6 " | 13.25 " | 19.25 " | 1.5 lbs |
| 8 " | 15.25 " | 23.25 " | 1.7 lbs |
| 10 " | 17.25 " | 27.25 " | 1.9 lbs |
| 12 " | 19.25 " | 31.25 " | 2.1 lbs |

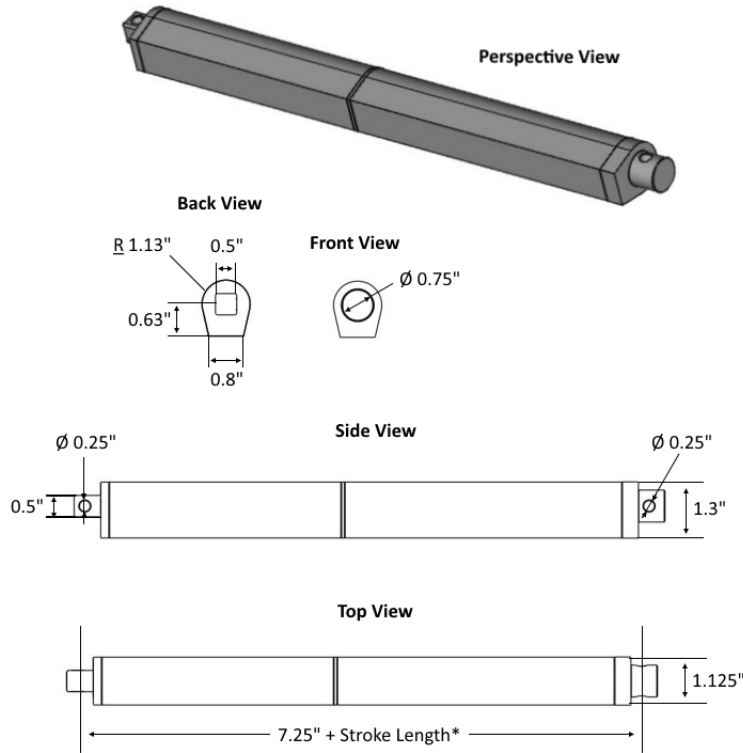

*Stroke length tolerance = $\pm 0.125"$

FA-RMS-15

Performance Graphs

12V DC Speed vs Load

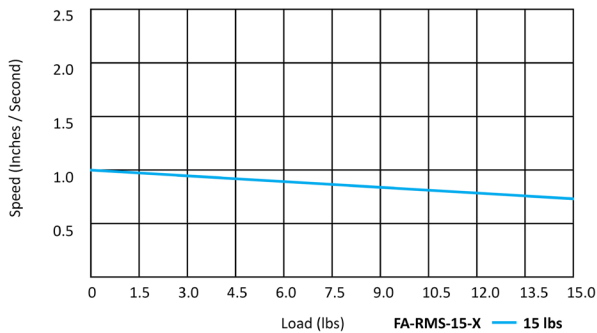

12V DC Current vs Load

