

HYDRAULIC BRAKE SERIES BRK

This is a closed-loop hydraulic brake without its own power source. It is normally associated with an ISO 15552 pneumatic cylinder. It consists of an oil-filled cylinder, one or more regulation valves and a tank compensating for oil leaks.

It is available in two sizes, the Ø40 and Ø63, and in different versions:

- with regulation in piston rod extension, in retraction or both
 - SKIP valve (slow/fast) or STOP valve or both, with NC or NO control
- After a certain operating time, the brake compensation tank needs to be topped up. Refer to the minimum mark on the dipstick. With the piston rod fully extended, the dipstick must project at least 15 mm from the tank cap. Use only DEXRON ATF hydraulic oil. During the first few work cycles, excess oil is ejected through a hole in the tank.

Regulation can be controlled remotely, as shown on page A4.26

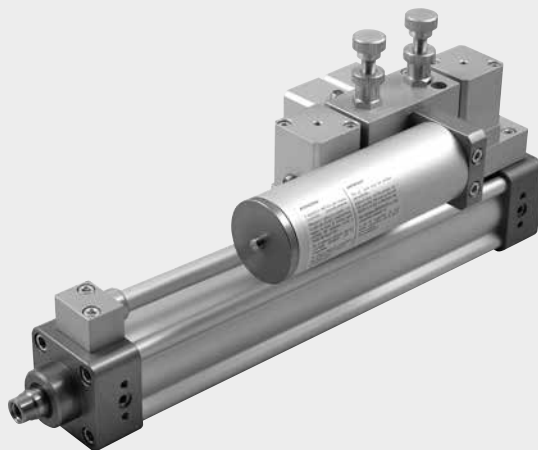

TECHNICAL DATA		Ø40	Ø63
Operating temperature	°C	-10 to +70	
Fluid		Oil, brake fluid provided	
Maximum applicable load	N	7000	25000
Speed	mm/min	See attached diagram	
Standard strokes	mm	50, 100, 150, 200, 250, 300, 350, 400, 450, 500 special strokes up to 1000 on request.	
Versions		Regulation in piston rod extension and/or retraction. Remote regulation. SKIP valves. STOP valves. NC or NO. Tank in-line or on the side	
Cylinder fixing		Using flange kit	-
ISO 15552 cylinders connected	mm	Ø40 to Ø100	Ø100 to Ø200

COMPONENTS

- PISTON ROD: thick chromed steel
- HEADS: anodized aluminium alloy
- PISTON ROD GASKET: NBR rubber
- PISTON ROD GUIDE BUSHING: steel strip with bronze and PTFE insert
- JACKET: drawn anodized aluminium alloy
- PISTON: aluminium alloy
- PISTON GASKET: NBR rubber
- OIL SEAL GASKET: polyurethane
- Static O-rings: NBR rubber
- SEALING DISK: plastic
- SPRINGS: zinc-plated steel
- SECURING/ASSEMBLY SCREW: self-threading screw (Tap Tite)
- OIL LEVEL STICK: zinc-plated steel
- OIL RECOVERY TANK
- VALVE for OIL FILLING
- FLOW REGULATION NEEDLE
- MINIMUM LEVEL

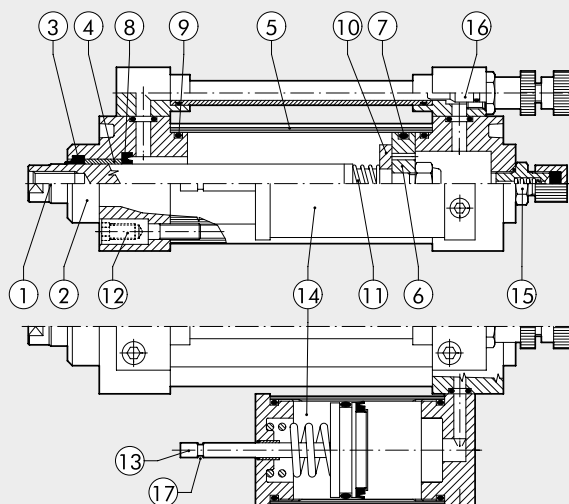

SPEED

The speed can be reached by coupling the BRK brake to a pneumatic cylinder. The diagrams show the indicative speed, which depends on the bore and feed pressure for the pneumatic cylinder. Average values for temperature of 20°C. The maximum speed increases with oil temperature, and vice versa.

Ø40 BRK BRAKE WITH REGULATION, SKIP OR REGULATION + SKIP VALVE(S)

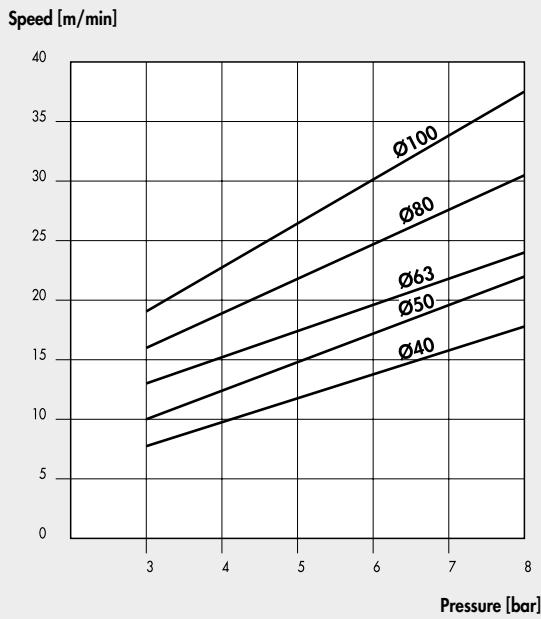

Ø40 BRK BRAKE WITH STOP OR REGULATION + STOP VALVE(S)

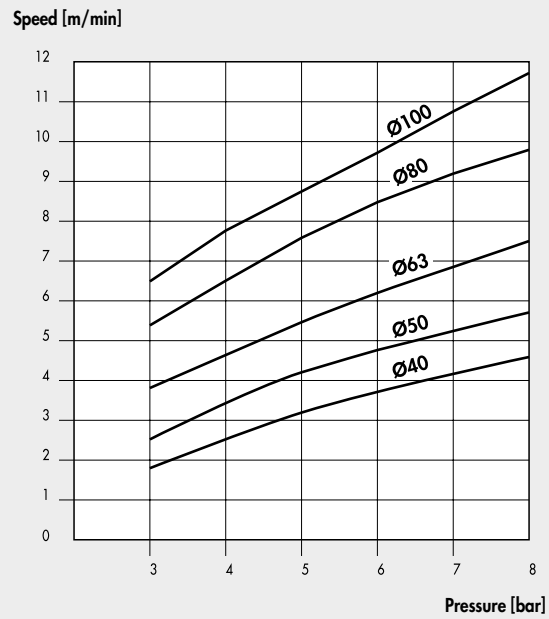

Ø63 BRK BRAKE WITH REGULATION, SKIP OR REGULATION + SKIP VALVE(S)

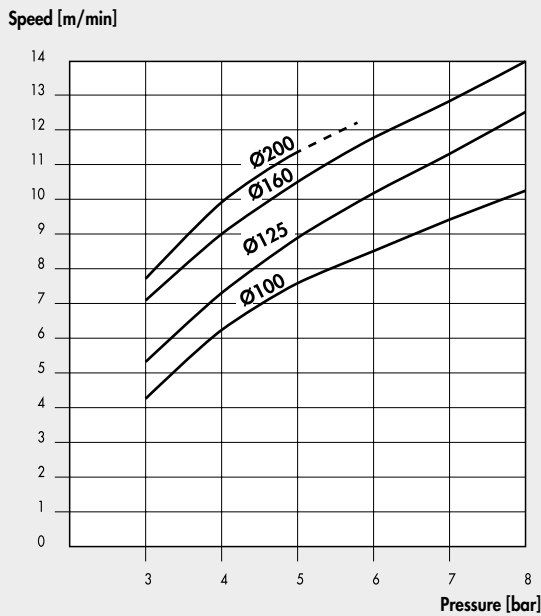

Ø63 BRK BRAKE WITH STOP OR REGULATION + STOP VALVE(S)

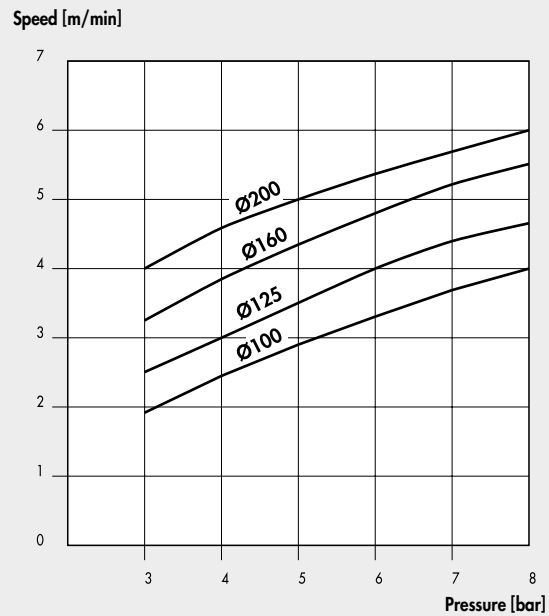

SKIP-STOP APPLICATION WITH VALVES

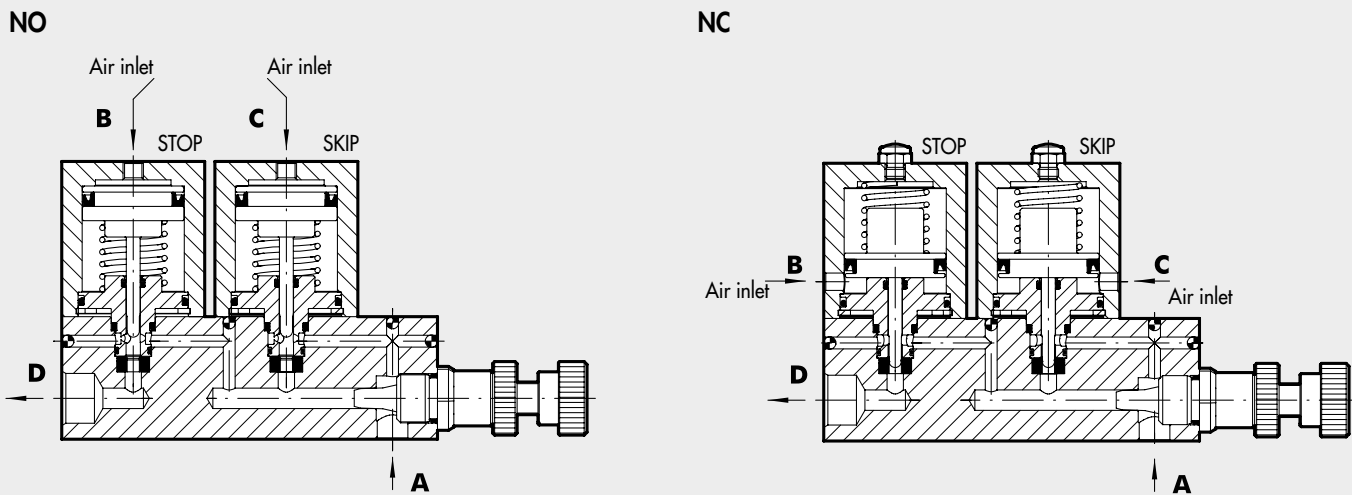

In normally-open (NO) valves, flow moves freely from A to D. When port C is supplied, this operates the SKIP valve and the fluid is forced through the bottleneck generated by the adjusting pin. When port B is supplied, this operates the STOP valve and interrupts the flow of fluid. In normally-closed NC valves, flow is normally inhibited. When port B is supplied, the fluid flows through but it is forced through the bottleneck generated by the adjusting pin. When port C is supplied, flow moves freely from A to D.

DIMENSIONS AND ORDERING CODES

HYDRAULIC BRAKE WITH REGULATION IN PISTON ROD EXTENSION



Symbol	Code	Ø
	W170001____	40
	W170001____63	63

____ = Enter the stroke

Weight [g]
 Ø40: For stroke 0 mm = 1340 g / Each mm = 4.2 g
 Ø63: For stroke 0 mm = 2340 g / Each mm = 8.7 g

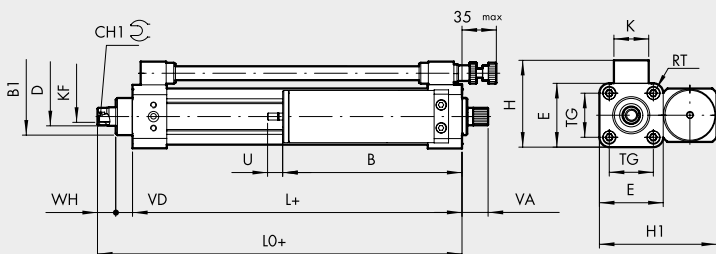

+ = ADD THE STROKE

Ø	B1	CH1	D	E	H	H1	K	KF	L	LO	RT	TG	VA	VD	WH	B		U max		
																Ø40	Ø63	Ø40	Ø63	
40	32	13	16	55	75	101	30	M10	84	114	M6	38	22.5	14.5	15.5	1 - 50	109	133	23	28
63	45	19	22	75	100	131	35	M16	96	126.5	M8	56.5	22.5	15	15.5	51 - 150	129	158	39	47
																151 - 250	154	178	55	67
																251 - 350	174	228	71	86
																351 - 450	204	248	87	105
																451 - 500	229	273	95	124

HYDRAULIC BRAKE WITH REGULATION IN PISTON ROD EXTENSION, IN-LINE TANK



Symbol	Code	Ø
	W170001___L	40
	W170001___63L	63

___ = Enter the stroke

Weight [g]

Ø40: For stroke 0 mm = 1300 g / Each mm = 4.2 g

Ø63: For stroke 0 mm = 2300 g / Each mm = 8.7 g

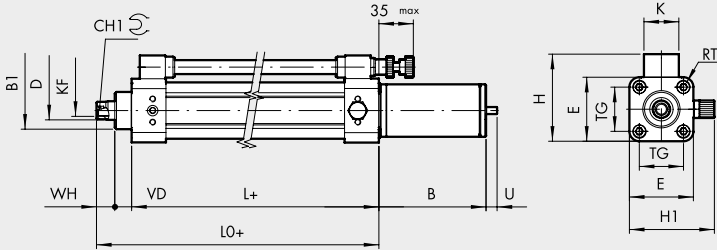

+ = ADD THE STROKE

Ø	B1	CH1	D	E	H	H1	K	KF	L	L0	RT	TG	VD	WH
40	32	13	16	55	75	73	30	M10	84	114	M6	38	14.5	15.5
63	45	19	22	75	100	93	35	M16	96	126.5	M8	56.5	15	15.5

Stroke	B		U max	
	Ø40	Ø63	Ø40	Ø63
1 - 50	92	112	23	28
51 - 150	112	137	39	47
151 - 250	137	157	55	67
251 - 350	157	187	71	86
351 - 450	187	212	87	105
451 - 500	212	252	95	124

HYDRAULIC BRAKE WITH REGULATION IN PISTON ROD RETRACTION



Symbol	Code	Ø
	W170011___	40
	W170011___63	63

___ = Enter the stroke

Weight [g]

Ø40: For stroke 0 mm = 1340 g / Each mm = 4.2 g

Ø63: For stroke 0 mm = 2340 g / Each mm = 8.7 g

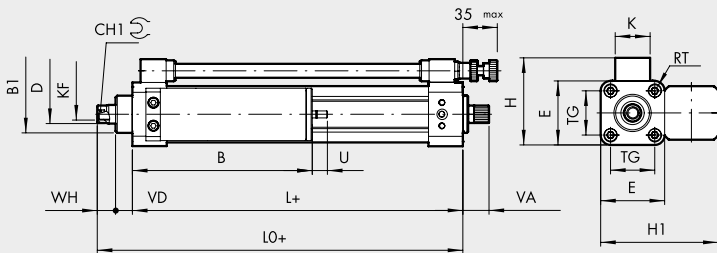

+ = ADD THE STROKE

Ø	B1	CH1	D	E	H	H1	K	KF	L	L0	RT	TG	VA	VD	WH
40	32	13	16	55	75	101	30	M10	84	114	M6	38	22.5	14.5	15.5
63	45	19	22	75	100	131	35	M16	96	126.5	M8	56.5	22.5	15	15.5

Stroke	B		U max	
	Ø40	Ø63	Ø40	Ø63
1 - 50	109	133	23	28
51 - 150	129	158	39	47
151 - 250	154	178	55	67
251 - 350	174	228	71	86
351 - 450	204	248	87	105
451 - 500	229	273	95	124

HYDRAULIC BRAKE WITH REGULATION IN PISTON ROD EXTENSION/RETRACTION

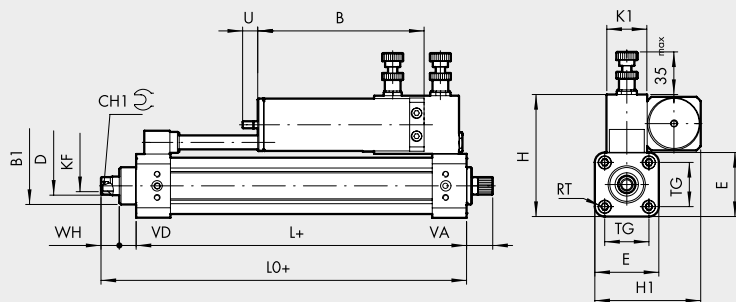

+ = ADD THE STROKE

Symbol	Code	Ø
	W170021 ____	40
	W170021 ____ 63	63

____ = Enter the stroke

Weight [g]

Ø40: For stroke 0 mm = 1710 g / Each mm = 4.2 g

Ø63: For stroke 0 mm = 2760 g / Each mm = 8.7 g

Ø	B1	CH1	D	E	H	H1	K1	KF	L	LO	RT	TG	VA	VD	WH
40	32	13	16	55	105	91	35	M10	84	114	M6	38	22.5	14.5	15.5
63	45	19	22	75	135	111	35	M16	96	126.5	M8	56.5	22.5	15	15.5

Stroke	B		U max	
	Ø40	Ø63	Ø40	Ø63
1 - 50	98	122	23	28
51 - 150	118	147	39	47
151 - 250	143	167	55	67
251 - 350	163	217	71	86
351 - 450	193	237	87	105
451 - 500	218	262	95	124

HYDRAULIC BRAKE WITH REGULATION IN EXTENSION + SKIP VALVE
HYDRAULIC BRAKE WITH REGULATION IN EXTENSION + STOP VALVE

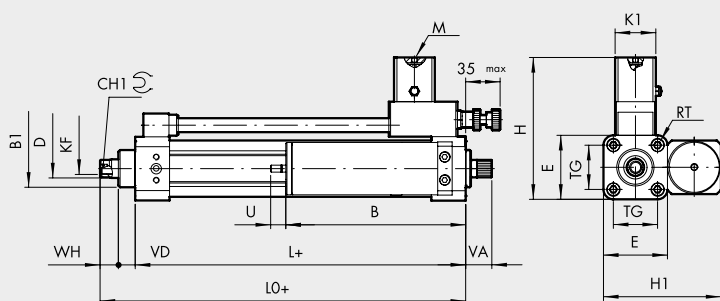
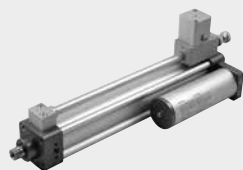

+ = ADD THE STROKE

Symbol	Code	Ø	Valve
	W170101 ____	40	SKIP NO
	W170101 ____ 63	63	SKIP NO

	W170201 ____	40	STOP NO
	W170201 ____ 63	63	STOP NO

	W170102 ____	40	SKIP NC
	W170102 ____ 63	63	SKIP NC

	W170202 ____	40	STOP NC
	W170202 ____ 63	63	STOP NC

____ = Enter the stroke

Weight [g]

Ø40: For stroke 0 mm = 1555 g / Each mm = 4.2 g

Ø63: For stroke 0 mm = 2620 g / Each mm = 8.7 g

Ø	B1	CH1	D	E	H	H1	K1	KF	L	LO	M	RT	TG	VA	VD	WH
40	32	13	16	55	123	101	35	M10	84	114	M5	M6	38	22.5	14.5	15.5
63	45	19	22	75	143	131	35	M16	96	126.5	M5	M8	56.5	22.5	15	15.5

Stroke	B		U max	
	Ø40	Ø63	Ø40	Ø63
1 - 50	109	133	23	28
51 - 150	129	158	39	47
151 - 250	154	178	55	67
251 - 350	174	228	71	86
351 - 450	204	248	87	105
451 - 500	229	273	95	124

HYDRAULIC BRAKE WITH REGULATION IN EXTENSION + SKIP VALVE, IN-LINE TANK
HYDRAULIC BRAKE WITH REGULATION IN EXTENSION + STOP VALVE, IN-LINE TANK

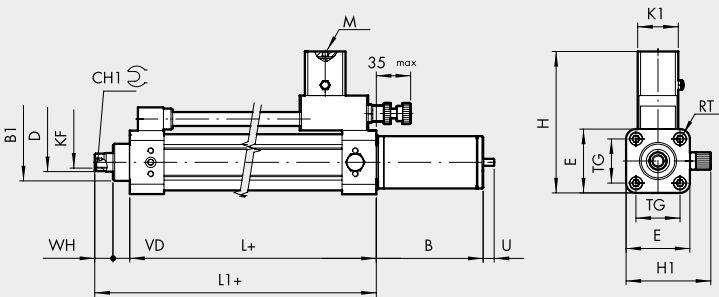

+ = ADD THE STROKE

Symbol	Code	Ø	Valve
	W170101___L	40	SKIP NO
	W170101___63L	63	SKIP NO
	W170201___L	40	STOP NO
	W170201___63L	63	STOP NO
	W170102___L	40	SKIP NC
	W170102___63L	63	SKIP NC
	W170202___L	40	STOP NC
	W170202___63L	63	STOP NC

___ = Enter the stroke

Weight [g]

Ø40: For stroke 0 mm = 1510 g / Each mm = 4.2 g
 Ø63: For stroke 0 mm = 2600 g / Each mm = 8.7 g

Ø	B1	CH1	D	E	H	H1	K1	KF	L	LO	M	RT	TG	VD	WH
40	32	13	16	55	123	73	35	M10	84	114	M5	M6	38	14.5	15.5
63	45	19	22	75	143	93	35	M16	96	126.5	M5	M8	56.5	15	15.5

Stroke	B		U max	
	Ø40	Ø63	Ø40	Ø63
1 - 50	92	112	23	28
51 - 150	112	137	39	47
151 - 250	137	157	55	67
251 - 350	157	187	71	86
351 - 450	187	212	87	105
451 - 500	212	252	95	124

HYDRAULIC BRAKE WITH REGULATION IN RETRACTION + SKIP VALVE
HYDRAULIC BRAKE WITH REGULATION IN RETRACTION + STOP VALVE

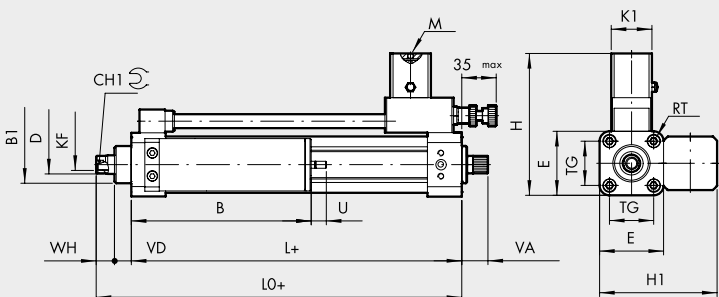

+ = ADD THE STROKE

Symbol	Code	Ø	Valve
	W170111___	40	SKIP NO
	W170111___63	63	SKIP NO
	W170211___	40	STOP NO
	W170211___63	63	STOP NO
	W170112___	40	SKIP NC
	W170112___63	63	SKIP NC
	W170212___	40	STOP NC
	W170212___63	63	STOP NC

___ = Enter the stroke

Weight [g]

Ø40: For stroke 0 mm = 1555 g / Each mm = 4.2 g
 Ø63: For stroke 0 mm = 2620 g / Each mm = 8.7 g

Ø	B1	CH1	D	E	H	H1	K1	KF	L	LO	M	RT	TG	VA	VD	WH
40	32	13	16	55	123	101	35	M10	84	114	M5	M6	38	22.5	14.5	15.5
63	45	19	22	75	143	131	35	M16	96	126.5	M5	M8	56.5	22.5	15	15.5

Stroke	B		U max	
	Ø40	Ø63	Ø40	Ø63
1 - 50	109	133	23	28
51 - 150	129	158	39	47
151 - 250	154	178	55	67
251 - 350	174	228	71	86
351 - 450	204	248	87	105
451 - 500	229	273	95	124

HYDRAULIC BRAKE WITH REGULATION IN EXTENSION + SKIP/STOP VALVES

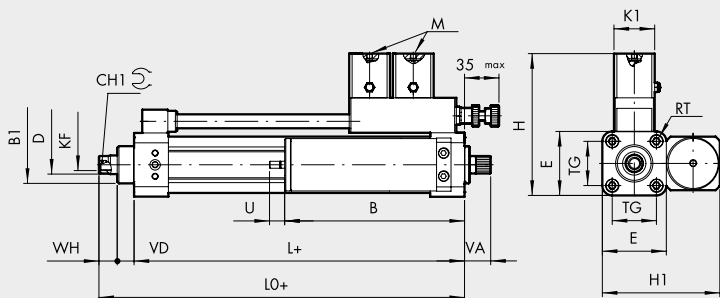

+ = ADD THE STROKE

Symbol	Code	Ø	Valve
	W170301____	40	SKIP/STOP NO
	W170301____63	63	SKIP/STOP NO
	W170302____	40	SKIP/STOP NC
	W170302____63	63	SKIP/STOP NC

____ = Enter the stroke

Weight [g]
 Ø40: For stroke 0 mm = 1730 g / Each mm = 4.2 g
 Ø63: For stroke 0 mm = 2850 g / Each mm = 8.7 g

Ø	B1	CH1	D	E	H	H1	K1	KF	L	LO	M	RT	TG	VA	VD	WH	B		U max	
																	Ø40	Ø63	Ø40	Ø63
40	32	13	16	55	123	101	35	M10	84	114	M5	M6	38	22.5	14.5	15.5	109	133	23	28
63	45	19	22	75	143	131	35	M16	96	126.5	M5	M8	56.5	22.5	15	15.5	129	158	39	47

Stroke	B		U max	
	Ø40	Ø63	Ø40	Ø63
1 - 50	109	133	23	28
51 - 150	129	158	39	47
151 - 250	154	178	55	67
251 - 350	174	228	71	86
351 - 450	204	248	87	105
451 - 500	229	273	95	124

HYDRAULIC BRAKE WITH REGULATION IN EXTENSION + SKIP/STOP VALVES, IN-LINE TANK

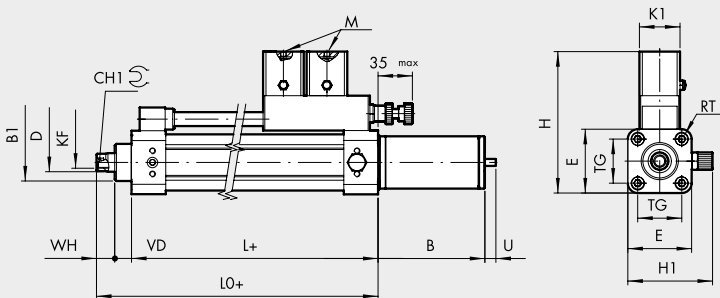

+ = ADD THE STROKE

Symbol	Code	Ø	Valve
	W170301____L	40	SKIP/STOP NO
	W170301____63L	63	SKIP/STOP NO
	W170302____L	40	SKIP/STOP NC
	W170302____63L	63	SKIP/STOP NC

____ = Enter the stroke

Weight [g]
 Ø40: For stroke 0 mm = 1690 g / Each mm = 4.2 g
 Ø63: For stroke 0 mm = 2800 g / Each mm = 8.7 g

Ø	B1	CH1	D	E	H	H1	K1	KF	L	LO	M	RT	TG	VD	WH	B		U max	
																Ø40	Ø63	Ø40	Ø63
40	32	13	16	55	123	73	35	M10	84	114	M5	M6	38	14.5	15.5	92	112	23	28
63	45	19	22	75	143	93	35	M16	96	126.5	M5	M8	56.5	15	15.5	112	137	39	47

Stroke	B		U max	
	Ø40	Ø63	Ø40	Ø63
1 - 50	92	112	23	28
51 - 150	112	137	39	47
151 - 250	137	157	55	67
251 - 350	157	187	71	86
351 - 450	187	212	87	105
451 - 500	212	252	95	124

HYDRAULIC BRAKE WITH REGULATION IN RETRACTION + SKIP/STOP VALVES

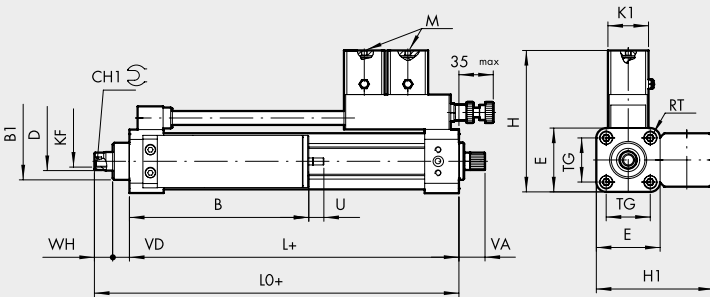

+ = ADD THE STROKE

Symbol	Code	Ø	Valve
	W170311 ____	40	SKIP/STOP NO
	W170311 ____ 63	63	SKIP/STOP NO
	W170312 ____	40	SKIP/STOP NC
	W170312 ____ 63	63	SKIP/STOP NC

____ = Enter the stroke

Weight [g]
 Ø40: For stroke 0 mm = 1730 g / Each mm = 4.2 g
 Ø63: For stroke 0 mm = 2850 g / Each mm = 8.7 g

Ø	B1	CH1	D	E	H	H1	K1	KF	L	LO	M	RT	TG	VA	VD	WH	B		U max		
																	Ø40	Ø63	Ø40	Ø63	
40	32	13	16	55	123	101	35	M10	84	114	M5	M6	38	22.5	14.5	15.5	109	133	23	28	
63	45	19	22	75	143	131	35	M16	96	126.5	M5	M8	56.5	22.5	15	15.5	129	158	39	47	
																		154	178	55	67
																		174	228	71	86
																		204	248	87	105
																		229	273	95	124

HYDRAULIC BRAKE WITH REGULATION IN EXTENSION/RETRACTION + EXTENSION SKIP VALVE

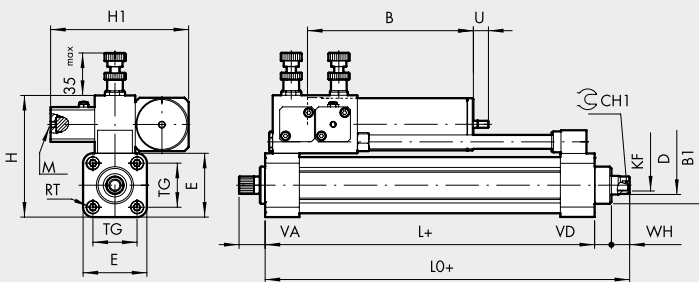

+ = ADD THE STROKE

Symbol	Code	Ø	Valve
	W17002A ____	40	SKIP NO
	W17002A ____ 63	63	SKIP NO
	W17002B ____	40	SKIP NC
	W17002B ____ 63	63	SKIP NC

____ = Enter the stroke

Weight [g]
 Ø40: For stroke 0 mm = 1850 g / Each mm = 4.2 g
 Ø63: For stroke 0 mm = 2910 g / Each mm = 8.7 g

Ø	B1	CH1	D	E	H	H1	KF	L	LO	M	RT	TG	VA	VD	WH	B		U max		
																Ø40	Ø63	Ø40	Ø63	
40	32	13	16	55	105	119	M10	84	114	M5	M6	38	22.5	14.5	15.5	98	122	23	28	
63	45	19	22	75	135	129	M16	96	126.5	M5	M8	56.5	22.5	15	15.5	118	147	39	47	
																	143	167	55	67
																	163	217	71	86
																	193	237	87	105
																	218	262	95	124

HYDRAULIC BRAKE WITH REGULATION IN EXTENSION/RETRACTION + RETRACTION SKIP VALVE

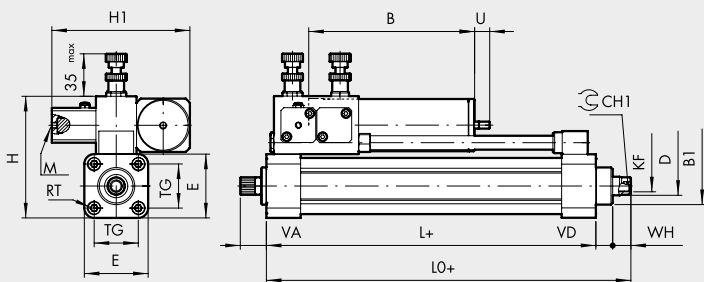

+ = ADD THE STROKE

Symbol	Code	Ø	Valve
	W17002C ____	40	SKIP NO
	W17002C ____ 63	63	SKIP NO
	W17002D ____	40	SKIP NC
	W17002D ____ 63	63	SKIP NC

____ = Enter the stroke

Weight [g]
 Ø40: For stroke 0 mm = 1850 g / Each mm = 4.2 g
 Ø63: For stroke 0 mm = 2910 g / Each mm = 8.7 g

Ø	B1	CH1	D	E	H	H1	KF	L	L0	M	RT	TG	VA	VD	WH
40	32	13	16	55	105	119	M10	84	114	M5	M6	38	22.5	14.5	15.5
63	45	19	22	75	135	129	M16	96	126.5	M5	M8	56.5	22.5	15	15.5

Stroke	B		U max	
	Ø40	Ø63	Ø40	Ø63
1 - 50	98	122	23	28
51 - 150	118	147	39	47
151 - 250	143	167	55	67
251 - 350	163	217	71	86
351 - 450	193	237	87	105
451 - 500	218	262	95	124

HYDRAULIC BRAKE WITH REGULATION IN EXTENSION/RETRACTION + EXTENSION STOP VALVE

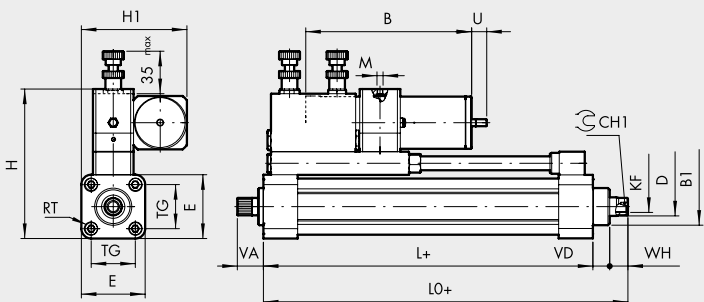

+ = ADD THE STROKE

Symbol	Code	Ø	Valve
	W170023 ____	40	STOP NO
	W170023 ____ 63	63	STOP NO
	W170024 ____	40	STOP NC
	W170024 ____ 63	63	STOP NC

____ = Enter the stroke

Note: Minimum stroke 100 mm

Weight [g]
 Ø40: For stroke 0 mm = 1990 g / Each mm = 4.2 g
 Ø63: For stroke 0 mm = 3230 g / Each mm = 8.7 g

Ø	B1	CH1	D	E	H	H1	KF	L	L0	M	RT	TG	VA	VD	WH
40	32	13	16	55	129	91	M10	84	114	M5	M6	38	22.5	14.5	15.5
63	45	19	22	75	160	111	M16	96	126.5	M5	M8	56.5	22.5	15	15.5

Stroke	B		U max	
	Ø40	Ø63	Ø40	Ø63
100 - 150	118	147	39	47
151 - 250	143	167	55	67
251 - 350	163	217	71	86
351 - 450	193	237	87	105
451 - 500	218	262	95	124

HYDRAULIC BRAKE WITH REGULATION IN EXTENSION/RETRACTION + RETRACTION STOP VALVE

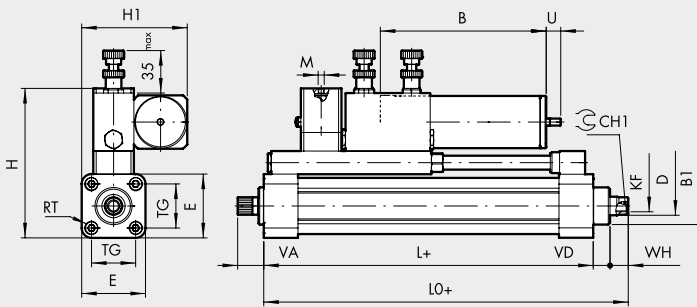

+ = ADD THE STROKE

Symbol	Code	Ø	Valve
	W170025 ____	40	STOP NO
	W170025 ____ 63	63	STOP NO
	W170026 ____	40	STOP NC
	W170026 ____ 63	63	STOP NC

____ = Enter the stroke
Note: Minimum stroke 100 mm

Weight [g]
 Ø40: For stroke 0 mm = 2080 g / Each mm = 4.2 g
 Ø63: For stroke 0 mm = 3230 g / Each mm = 8.7 g

Ø	B1	CH1	D	E	H	H1	KF	L	L0	M	RT	TG	VA	VD	WH
40	32	13	16	55	129	91	M10	84	114	M5	M6	38	22.5	14.5	15.5
63	45	19	22	75	160	111	M16	96	126.5	M5	M8	56.5	22.5	15	15.5

Stroke	B		U max	
	Ø40	Ø63	Ø40	Ø63
100 - 150	118	147	39	47
151 - 250	143	167	55	67
251 - 350	163	217	71	86
351 - 450	193	237	87	105
451 - 500	218	262	95	124

HYDRAULIC BRAKE WITH REGULATION IN EXTENSION/RETRACTION + DUAL STOP VALVE

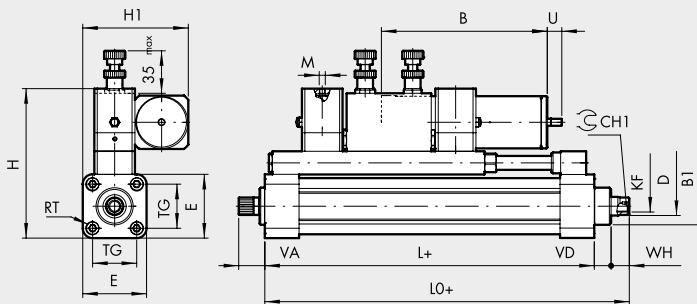
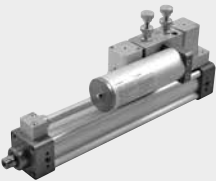

+ = ADD THE STROKE

Symbol	Code	Ø	Valve
	W170221 ____	40	STOP NO
	W170221 ____ 63	63	STOP NO
	W170222 ____	40	STOP NC
	W170222 ____ 63	63	STOP NC

____ = Enter the stroke
Note: Minimum stroke 150 mm

Weight [g]
 Ø40: For stroke 0 mm = 2260 g / Each mm = 4.2 g
 Ø63: For stroke 0 mm = 3560 g / Each mm = 8.7 g

Ø	B1	CH1	D	E	H	H1	KF	L	L0	M	RT	TG	VA	VD	WH
40	32	13	16	55	129	91	M10	84	114	M5	M6	38	22.5	14.5	15.5
63	45	19	22	75	160	111	M16	96	126.5	M5	M8	56.5	22.5	15	15.5

Stroke	B		U max	
	Ø40	Ø63	Ø40	Ø63
150	118	147	39	47
151 - 250	143	167	55	67
251 - 350	163	217	71	86
351 - 450	193	237	87	105
451 - 500	218	262	95	124

HYDRAULIC BRAKE WITH REGULATION IN EXTENSION/RETRACTION + DUAL SKIP VALVE

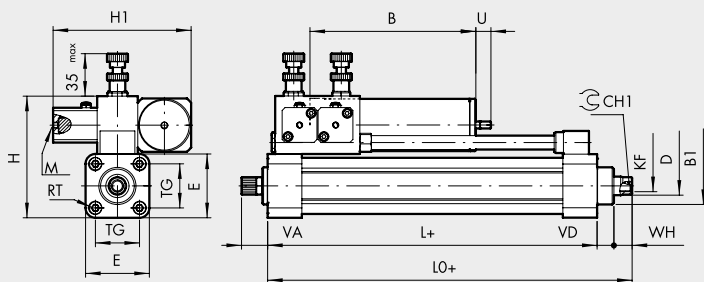

+ = ADD THE STROKE

Symbol	Code	Ø	Valve
	W170121 ____	40	SKIP NO
	W170121 ____ 63	63	SKIP NO
	W170122 ____	40	SKIP NC
	W170122 ____ 63	63	SKIP NC

____ = Enter the stroke

Weight [g]
 Ø40: For stroke 0 mm = 1850 g / Each mm = 4.2 g
 Ø63: For stroke 0 mm = 3050 g / Each mm = 8.7 g

Ø	B1	CH1	D	E	H	H1	KF	L	L0	M	RT	TG	VA	VD	WH
40	32	13	16	55	105	119	M10	84	114	M5	M6	38	22.5	14.5	15.5
63	45	19	22	75	135	129	M16	96	126.5	M5	M8	56.5	22.5	15	15.5

Stroke	B		U max	
	Ø40	Ø63	Ø40	Ø63
1 - 50	98	122	23	28
51 - 150	118	147	39	47
151 - 250	143	167	55	67
251 - 350	163	217	71	86
351 - 450	193	237	87	105
451 - 500	218	262	95	124

HYDRAULIC BRAKE WITH REGULATION IN EXTENSION/RETRACTION + DUAL SKIP VALVE + PISTON ROD EXTENSION STOP VALVE

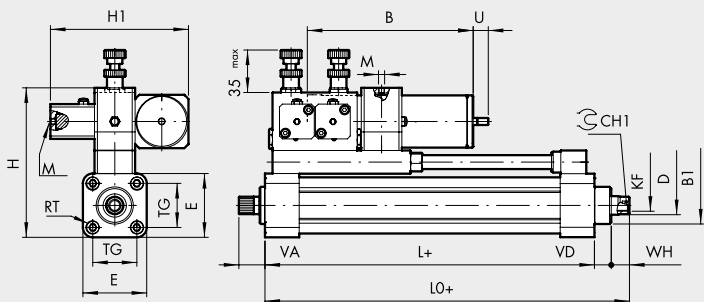

+ = ADD THE STROKE

Symbol	Code	Ø	Valve
	W170123 ____	40	SKIP + STOP NO
	W170123 ____ 63	63	SKIP + STOP NO
	W170124 ____	40	SKIP + STOP NC
	W170124 ____ 63	63	SKIP + STOP NC

____ = Enter the stroke

Note: Minimum stroke 100 mm

Weight [g]
 Ø40: For stroke 0 mm = 2110 g / Each mm = 4.2 g
 Ø63: For stroke 0 mm = 3490 g / Each mm = 8.7 g

Ø	B1	CH1	D	E	H	H1	KF	L	L0	M	RT	TG	VA	VD	WH
40	32	13	16	55	129	119	M10	84	114	M5	M6	38	22.5	14.5	15.5
63	45	19	22	75	160	129	M16	96	126.5	M5	M8	56.5	22.5	15	15.5

Stroke	B		U max	
	Ø40	Ø63	Ø40	Ø63
100 - 150	118	147	39	47
151 - 250	143	167	55	67
251 - 350	163	217	71	86
351 - 450	193	237	87	105
451 - 500	218	262	95	124

HYDRAULIC BRAKE WITH REGULATION IN EXTENSION/RETRACTION + DUAL SKIP VALVE + PISTON ROD RETRACTION STOP VALVE

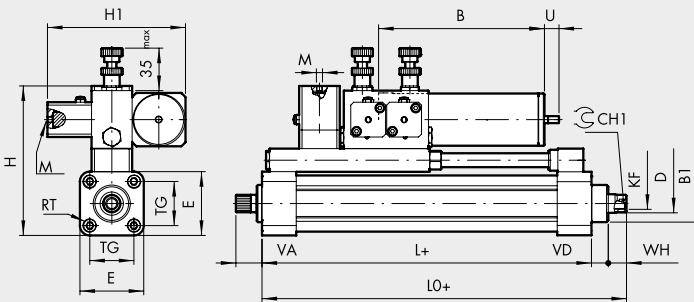

+ = ADD THE STROKE

Symbol	Code	Ø	Valve
	W170125 ____	40	SKIP + STOP NO
	W170125 ____63	63	SKIP + STOP NO
	W170126 ____	40	SKIP + STOP NC
	W170126 ____63	63	SKIP + STOP NC

____ = Enter the stroke
Note: Minimum stroke 100 mm

Weight [g]
 Ø40: For stroke 0 mm = 2210 g / Each mm = 4.2 g
 Ø63: For stroke 0 mm = 3490 g / Each mm = 8.7 g

Ø	B1	CH1	D	E	H	H1	KF	L	L0	M	RT	TG	VA	VD	WH
40	32	13	16	55	129	119	M10	84	114	M5	M6	38	22.5	14.5	15.5
63	45	19	22	75	160	129	M16	96	126.5	M5	M8	56.5	22.5	15	15.5

Stroke	B		U max	
	Ø40	Ø63	Ø40	Ø63
100 - 150	118	147	39	47
151 - 250	143	167	55	67
251 - 350	163	217	71	86
351 - 450	193	237	87	105
451 - 500	218	262	95	124

HYDRAULIC BRAKE WITH REGULATION IN EXTENSION/RETRACTION + DUAL SKIP VALVE + DUAL STOP VALVE

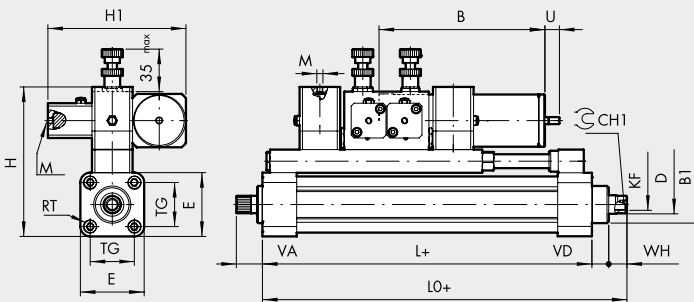

+ = ADD THE STROKE

Symbol	Code	Ø	Valve
	W170321 ____	40	SKIP + STOP NO
	W170321 ____63	63	SKIP + STOP NO
	W170322 ____	40	SKIP + STOP NC
	W170322 ____63	63	SKIP + STOP NC

____ = Enter the stroke
Note: Minimum stroke 150 mm

Weight [g]
 Ø40: For stroke 0 mm = 2415 g / Each mm = 4.2 g
 Ø63: For stroke 0 mm = 3820 g / Each mm = 8.7 g

Ø	B1	CH1	D	E	H	H1	KF	L	L0	M	RT	TG	VA	VD	WH
40	32	13	16	55	129	119	M10	84	114	M5	M6	38	22.5	14.5	15.5
63	45	19	22	75	160	129	M16	96	126.5	M5	M8	56.5	22.5	15	15.5

Stroke	B		U max	
	Ø40	Ø63	Ø40	Ø63
150	118	147	39	47
151 - 250	143	167	55	67
251 - 350	163	217	71	86
351 - 450	193	237	87	105
451 - 500	218	262	95	124

KEY TO CODES

W 1 7 0		1		0		1		0300 STROKE		L		◆ R1500	
W170	BRK hydraulic brake	0	Regulation	0	Extension	1	No valve or NO	Enter the desired stroke in four digits (e.g. 0500 for stroke 500)		–	∅ 40		
		1	Regulation + SKIP	1	Retraction	2	NC	● L	∅ 40 In-line tank				
		2	Regulation + STOP	2	Extension and retraction	* 3	+ STOP NO in extension	63	∅ 63				
		3	Regulation + SKIP + STOP			* 4	+ STOP NC in extension	● 63L	∅ 63 In-line tank				
						* 5	+ STOP NO in retraction						
						* 6	+ STOP NC in retraction						
						▲ A	+ SKIP NO in extension						
						▲ B	+ SKIP NC in extension						
						▲ C	+ SKIP NO in retraction						
						▲ D	+ SKIP NC in retraction						

- Only for versions with piston rod regulation in extension
- * In combination with regulation in extension/retraction or regulation + SKIP in extension/retraction
- ▲ In combination with regulation in extension/retraction or regulation + STOP in extension/retraction
- ◆ Execution with remote control only, see page A4.26

NOTES

ACCESSORIES

FLANGE FOR MOUNTING HYDRAULIC BRAKE Ø 40 WITH ISO 15552 CYLINDER

Ø 40

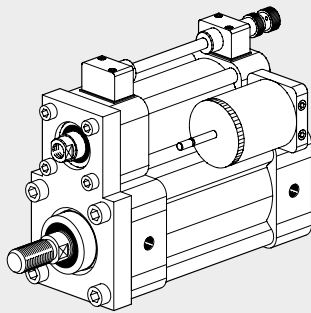
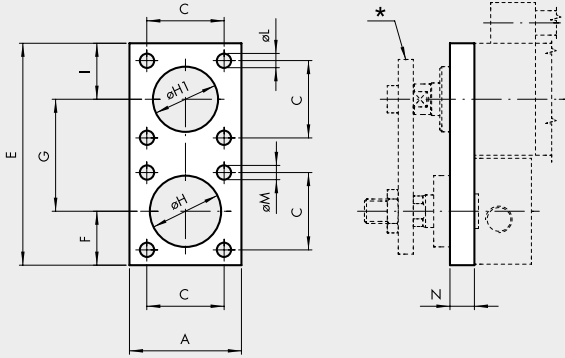

Ø 50-63-80-100

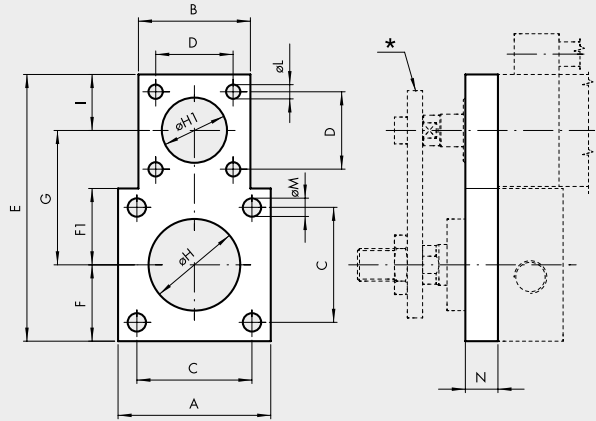

* Piston rod connection plate.

Depending on the cylinder size and operating pressure, it may be necessary for the plate connecting the two piston rods to be guided externally in order to withstand the bending moment due to braking. The table shows the minimum pressure "p", above which it is advisable to guide the plate.

Code	Ø	A	B	C	D	E	F	F1	G	ØH	ØH1	I	ØL	ØM	N	Weight [g]	p min [bar]
W0950402012	40	55	-	38	38	109	26.5	-	55	35	32	27.5	7	7	12	418	10
W0950502012	50	65	55	46.5	38	121	32.5	32.5	61	40	32	27.5	7	9	12	540	10
W0950632012	63	75	55	56.5	38	131	37.5	37.5	66	45	32	27.5	7	9	15	792	6
W0950802012	80	95	55	72	38	151	47.5	47.5	76	45	32	27.5	7	11	15	1216	3
W0951002012	100	112	55	89	38	168	56	56	84.5	55	32	27.5	7	11	15	1535	2

Note: 1 pc. per pack complete with 8 screws

FLANGE SCREW KIT FOR HYDRAULIC BRAKE Ø 40

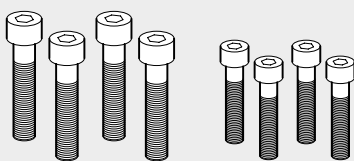

Code	Description	Weight [g]
W0950402111	Kit BRK-P/C-040	58
W0950502111	Kit BRK-P/C-050	93
W0950632111	Kit BRK-P/C-063	97
W0950802111	Kit BRK-P/C-080-100	151

Note: code corresponds to 8 screws

INTEGRATED HYDRAULIC BRAKE

The integrated hydraulic brake is comprised of a pneumatic cylinder that acts as an actuator and an oleo-dynamic circuit that acts as a brake. The dimensions of the pneumatic cylinder comply with ISO 15552. The hydraulic circuit is comprised of a brake fluid tank and one or two flow regulation pins. It can mount one or more (slow-fast) SKIP or STOP valves that are normally open (NO) or normally closed (NC), for the piston rod extension and retraction.

The basic feature of this device is that the driving force and the braking force are coaxial, so they do not generate undesired bending moments on the piston rod and the external structures connected to it. Due to its conception, this brake is particularly compact and has reduced dimensions compared to BRK external hydraulic brakes.

After a certain operating time, the brake fluid tank must be topped up with oil. This needs doing when the oil level reaches the minimum mark on the rod. With the piston rod right out, the minimum level mark must not project less than 8-10 mm from the cap.

Always use DEXRON ATF hydraulic oil or another compatible product.

During the first operating cycles, excess oil is expelled through a hole in the tank.

Regulation can be controlled remotely, as shown on page **A4.26**



TECHNICAL DATA		Ø50	Ø63	Ø80	Ø100
Operating pressure	bar	2 to 8			
	MPa	0.2 to 0.8			
NC valve actuation pressure	psi	29 to 116			
	bar	3 to 8			
	MPa	0.3 to 0.8			
	psi	43.5 to 116			
Operating temperature range	°C	-10 to +70			
	°F	14 to 156			
Pneumatic circuit fluid		Lubricated or unlubricated filtered air.			
Hydraulic circuit fluid		DEXRON ATF - the list of compatible oils is available on the web site www.metalwork.it			
Thrust force generated at 6 bar	N	1109	1801	2946	4521
Pull force generated at 6 bar	N	883	1292	2437	3756
Maximum load which can be applied from outside while the rod is lock	N				
• Version without valves and with closed pins:					
Thrust Load on the rod		6000			7000
Traction Load on the rod		5000			6000
• Version with STOP NC valves not operated:					
Thrust Load on the rod		6000			7000
Traction Load on the rod		5000			6000
• Version with STOP NO valves operated at 6 bar:					
Thrust Load on the rod		6000			7000
Traction Load on the rod		5000			6000
• Version with STOP NO valves operated at 8 bar:					
Thrust Load on the rod		6000			7000
Traction Load on the rod		5000			6000
Speeds at 6 bar and 20°C		See charts on the following pages			
Standard strokes		50, 100, 150, 200, 250, 300, 350, 400, 450, 500. Other special strokes up to 500 available on request.			
Valve combinations		Piston-out, piston-in and dual regulation. Remote regulation. The following combinations of valves can be mounted on each regulated section: STOP NO, STOP NC, SKIP NO, SKIP NC, DOUBLE STOP NO, DOUBLE STOP NC, DOUBLE SKIP NO, DOUBLE SKIP NC, STOP NO+STOP NC, SKIP NO+SKIP NC, STOP NO+SKIP NO, STOP NC+SKIP NC, STOP NO+SKIP NC, STOP NC+SKIP NO All versions are provided with a magnet			
Sensor magnet					

COMPONENTS

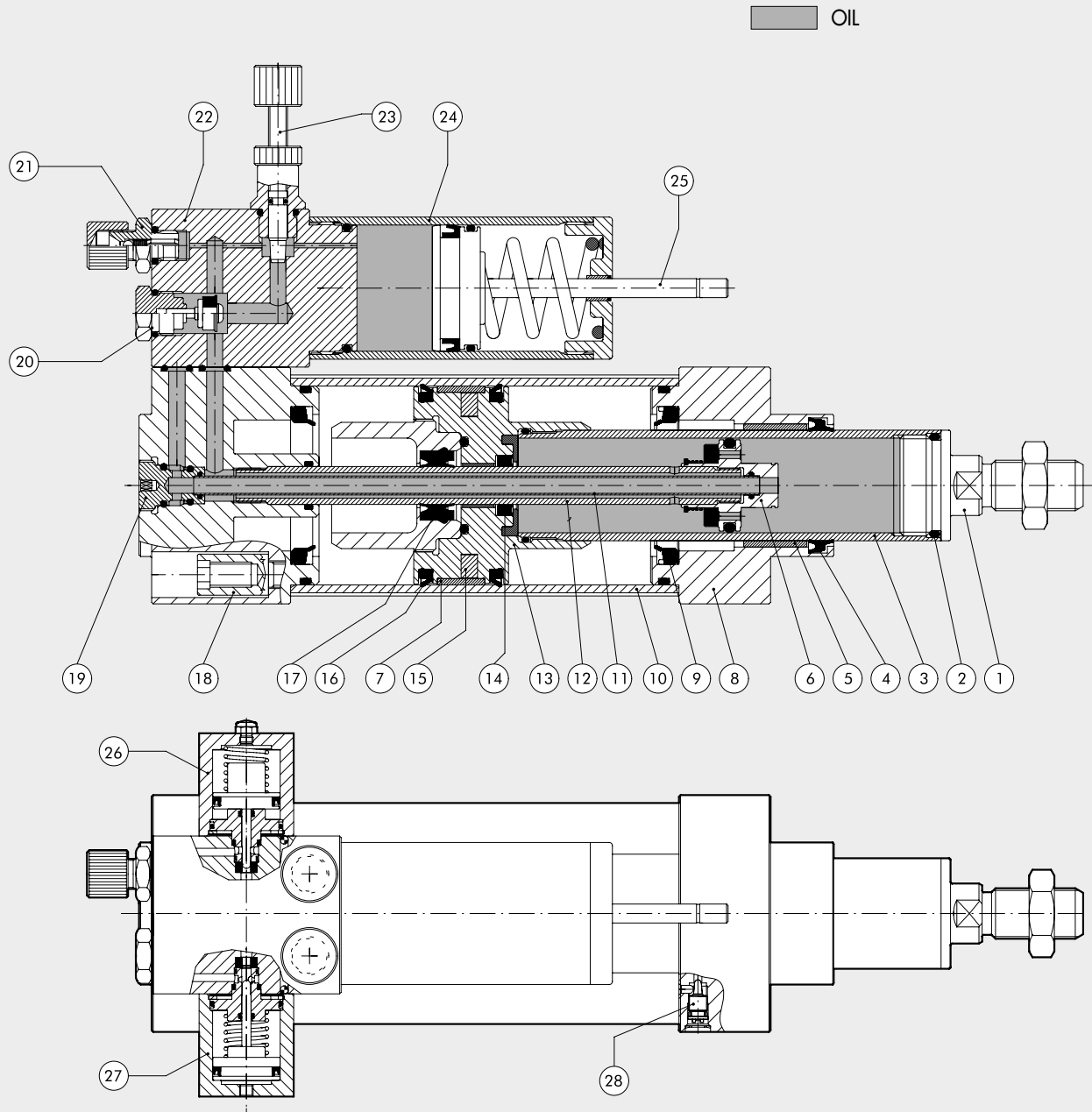

- | | | |
|--|---|---------------------------------------|
| ① GUIDE HOLD: AISI 303 stainless steel | ⑩ JACKET: anodized and calibrated aluminium section | ⑲ BUSH: nickel-plated brass |
| ② O-RING: NBR | ⑪ INTERNAL PIPE: brass | ⑳ CHECK VALVE |
| ③ PISTON ROD: thickly chromed steel | ⑫ INTERMEDIATE PIPE: steel | ㉑ OIL FILLING VALVE |
| ④ PISTON ROD GASKET: polyurethane | ⑬ PISTON: aluminium | ㉒ REGULATION UNIT: anodized aluminium |
| ⑤ GUIDE BUSHING: steel strip with bronze and PTFE insert | ⑭ PISTON ROD GASKET: polyurethane | ㉓ REGULATION PIN |
| ⑥ INSIDE PISTON: brass | ⑮ MAGNET: plastoferrite | ㉔ OIL RECOVERY TANK |
| ⑦ GUIDE RING: PTFE | ⑯ PISTON GASKET: NBR | ㉕ OIL LEVEL ROD: zinc-plated steel |
| ⑧ HEAD: anodized aluminium | ⑰ PISTON ROD GASKET: polyurethane | ㉖ NC VALVE |
| ⑨ CUSHIONING GASKET: NBR | ⑱ SECURING/ASSEMBLY SCREW: self-tapping | ㉗ NO VALVE |
| | | ㉘ CUSHIONING PIN |

SPEED

Maximum speed reached. The diagrams show the indicative speed, which depends on the bore and feed pressure. Average values for temperature of 20°C. The maximum speed increases with oil temperature, and vice versa.

INTEGRATED HYDRAULIC BRAKE WITH REGULATION IN EXTENSION, IN RETRACTION OR DUAL

Speed [m/min]

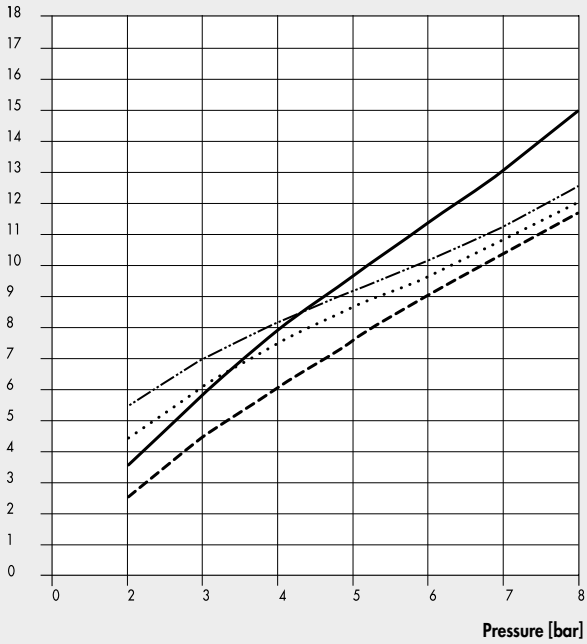

———— Ø50 ·········· Ø80
 - - - - - Ø63 - · - · - · Ø100

INTEGRATED HYDRAULIC BRAKE WITH VALVES STOP

Speed [m/min]

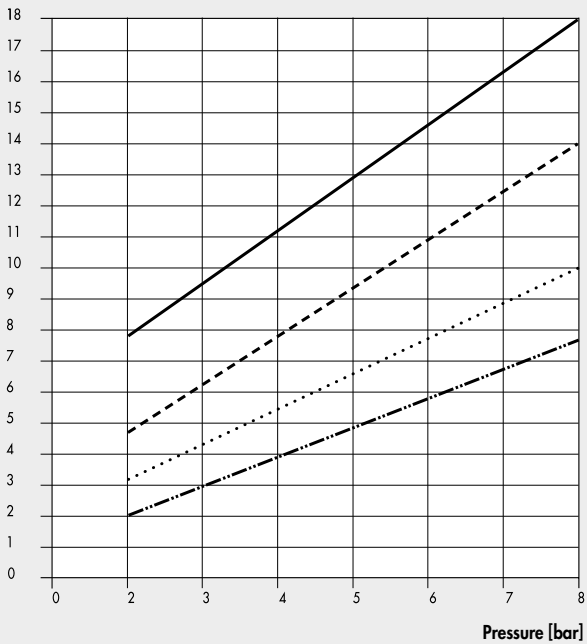

———— Ø50 in extension ·········· Ø63 in extension
 - - - - - Ø50 in retraction - · - · - · Ø63 in retraction

Speed [m/min]

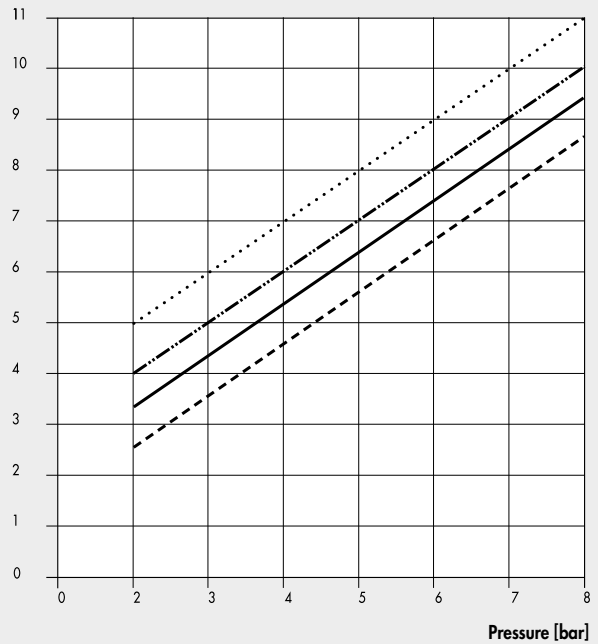

———— Ø80 in extension ·········· Ø100 in extension
 - - - - - Ø80 in retraction - · - · - · Ø100 in retraction

INTEGRATED HYDRAULIC BRAKE WITH VALVES SKIP AND WITH VALVES SKIP AND STOP

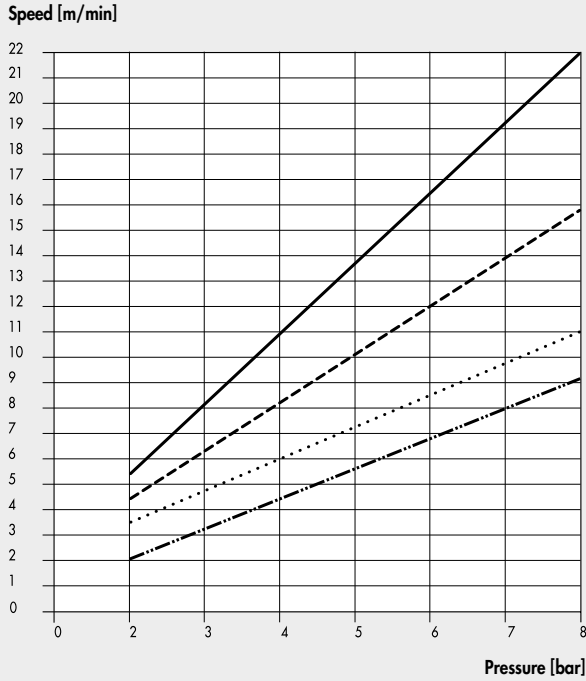

_____ Ø50 in extension Ø63 in extension
 - - - - - Ø50 in retraction - · - · - · - Ø63 in retraction

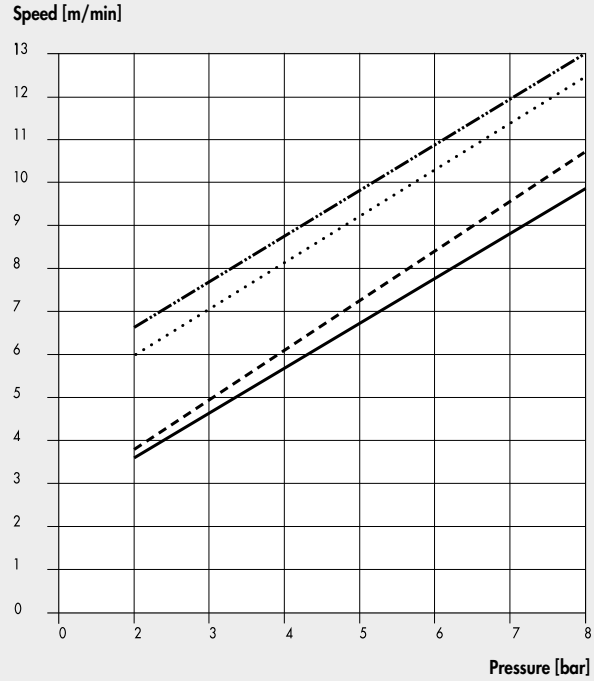

_____ Ø80 in extension Ø100 in extension
 - - - - - Ø80 in retraction - · - · - · - Ø100 in retraction

SKIP-STOP APPLICATION WITH VALVES

NO

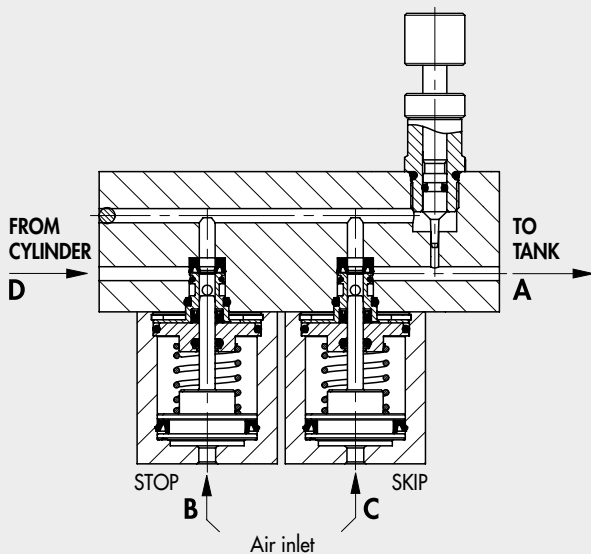

In normally-open (NO) valves, flow moves freely from A to D. When port C is supplied, this operates the SKIP valve and the fluid is forced through the bottleneck generated by the adjusting pin. When port B is supplied, this operates the STOP valve and interrupts the flow of fluid.

NC

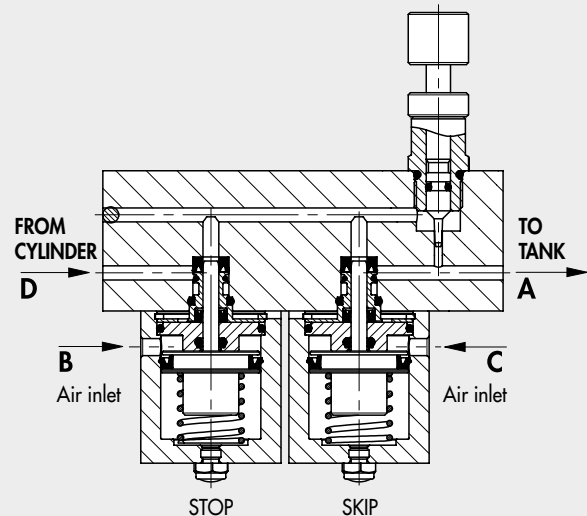

In normally-closed NC valves, flow is normally inhibited. When port B is supplied, the fluid flows through but it is forced through the bottleneck generated by the adjusting pin. When port C is supplied, flow moves freely from A to D.

DIMENSIONS OF THE VARIOUS VERSIONS

+ = ADD THE STROKE

① SLOTS FOR SLIM SENSOR (ONLY ON THE UTILITY PORTS SIDE)

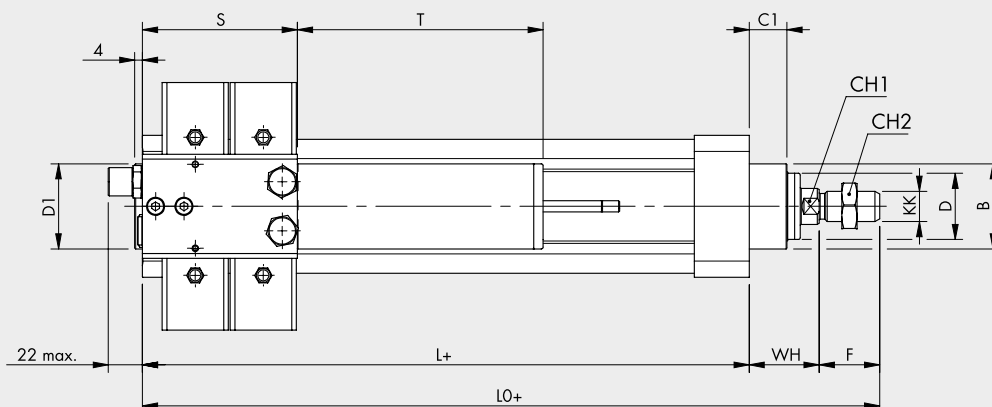
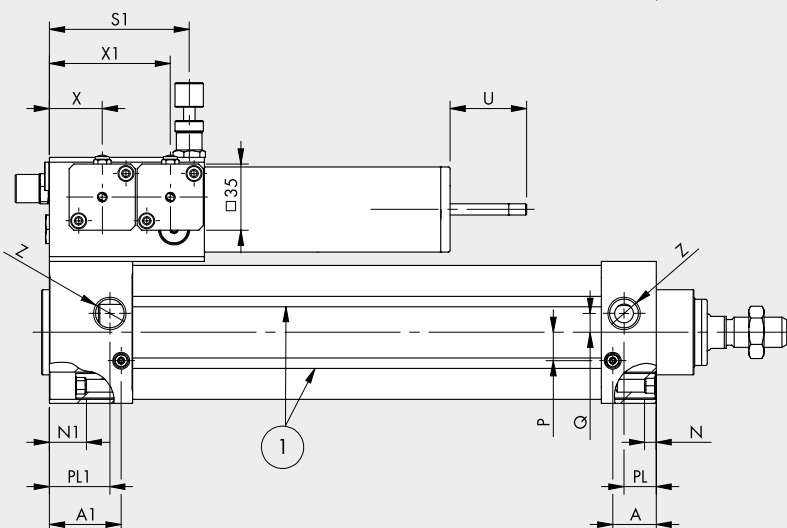
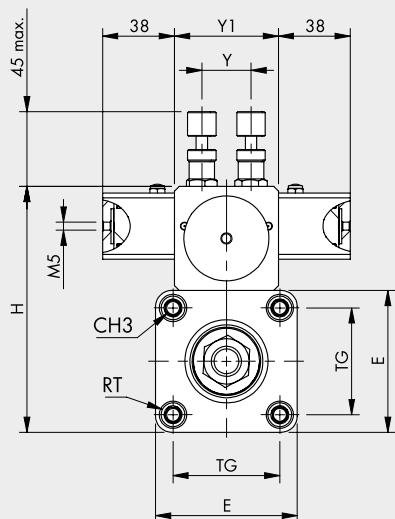

Stroke	Ø 50-63-80		Ø 100	
	T	U max	T	U max
50	106	25	150	30
100	131	30	150	38
150	131	35	180	46
200	171	40	180	54
250	171	45	220	62
300	171	50	220	70
350	216	55	245	78
400	216	60	245	86
450	301	65	345	94
500	301	70	345	102

Type	Ø 50-63-80		Ø 100	
	S	S1	S	S1
Regulation only	50	41	65	50
1 valve for side	50	41	65	50
2 valve for side	82	74	105	90

Ø	A	A1	B	C1	CH1	CH2	CH3	KK	D	D1	E	F	H	L	L0	N	N1	P	PL	PL1	Q	RT	TG	WH	X	X1	Y	Y1	Z
50	28	38	40	15	17	24	8	M16x1.5	25	45	65	32	120	128	192	5.5	19	11	22	32	8	M8	46.5	32	28	64	26	55	G1/4
63	23	38	45	20	17	24	8	M16x1.5	35	45	75	32	130	121	190	5.5	19	15	17	32	10	M8	56.5	37	28	64	26	55	G3/8
80	25	36	45	16	17	24	10	M16x1.5*	35	45	95	32	150	125	190	6	15	15	21	32	10	M10	72	33	28	64	26	55	G3/8
100	38	50	60	30	22	30	10	M20x1.5	45	55	110	40	175	172	261	20.5	32.5	15	35	47	10	M10	89	49	40	80	30	65	G1/2

* ATTENTION: thread not to ISO 15552

KEY TO CODES

W 1 7 3	2	3	1	0	0 5 0 0	◆ R1500
INTEGRATED BRAKE	REGULATION	PISTON ROD EXTENSION CONTROL VALVES	PISTON ROD RETRACTION CONTROL VALVES	BORE	STROKE	
W173 Integrated brake	0 Out 1 In 2 Dual	0 Without valves 1 Stop NO 2 Stop NC 3 Skip NO 4 Skip NC 5 Stop NO Skip NO 6 Stop NO Skip NC 7 Stop NC Skip NO 8 Stop NC Skip NC	0 Without valves 1 Stop NO 2 Stop NC 3 Skip NO 4 Skip NC 5 Stop NO Skip NO 6 Stop NO Skip NC 7 Stop NC Skip NO 8 Stop NC Skip NC	A Ø 50 0 Ø 63 1 Ø 80 2 Ø 100	Specify the desired stroke in 4 digits (e.g. 0500 for stroke 500)	

N.B. With at least one extension control valve and one retraction control valve, type W1732__ is required.
◆ Execution with remote control only, see page A4.26

ACCESSORIES: FIXINGS

FOOT - MODEL A

+ = ADD THE STROKE

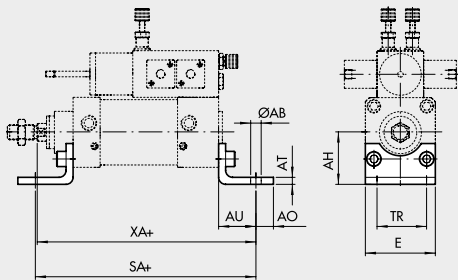

Code	Ø	Ø AB	AH	AO	AT	AU	TR	E	XA	SA	Weight [g]
W0950502001	50	9	45	15	5	32	45	65	192	192	162
W0950632001	63	9	50	15	5	32	50	75	190	185	266
W0950802001	80	12	63	20	6	41	63	95	199	207	456

Note: Individually packed with 2 screws.

N.B.: for fixing the rear head is necessary to use:
- Ø50-63 n. 4 screws M8x40 UNI 5931 (see kit 0950636092)
- Ø80 n. 4 screws M10x40 UNI 5931

FEMALE HINGE - MODEL B

+ = ADD THE STROKE

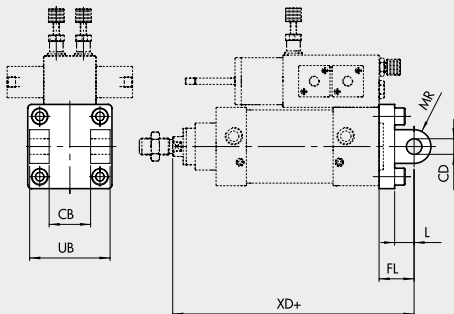

Code	Ø	UB	CB ^{H14}	FL	CD ^{H9}	XD	MR	L	Weight [g]
W0950502003	50	60	32	27	12	187	12	15	252
W0950632003	63	70	40	32	16	190	16	20	394
W0950802003	80	90	50	36	16	194	16	20	670
W0951002003	100	110	60	41	20	262	20	25	1085

Note: Supplied with 4 screws, 4 washers, 2 snap rings and 1 pin.

N.B.: for fixing the rear head is necessary to use:
- Ø50-63 n. 4 screws M8x40 UNI 5931 (see kit 0950636092)
- Ø80 n. 4 screws M10x40 UNI 5931
- Ø100 n. 4 screws M10x60 UNI 5931 (see kit 0951006092)

MALE HINGE - MODEL BA

+ = ADD THE STROKE

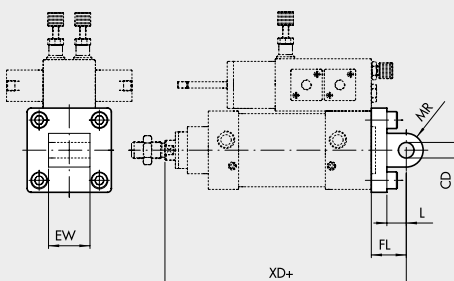

Code	Ø	EW	FL	MR	CD ^{H9}	L	XD	Weight [g]
W0950502004	50	32	27	13	12	15	187	220
W0950632004	63	40	32	17	16	20	190	316
W0950802004	80	50	36	17	16	20	194	578
W0951002004	100	60	41	21	20	25	262	850

Note: Supplied with 4 screws.

N.B.: for fixing the rear head is necessary to use:
- Ø50-63 n. 4 screws M8x40 UNI 5931 (see kit 0950636092)
- Ø80 n. 4 screws M10x40 UNI 5931
- Ø100 n. 4 screws M10x60 UNI 5931 (see kit 0951006092)

ARTICULATED MALE HINGE - MODEL BAS

+ = ADD THE STROKE

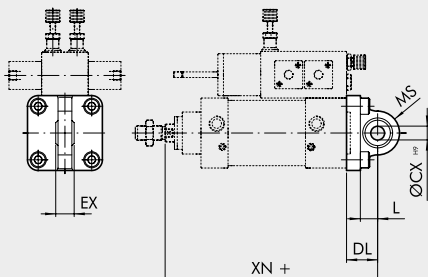

Code	Ø	DL	MS	L	XN	ØCX	EX	Weight [g]
W0950502006	50	27	21	15	187	12	16	236
W0950632006	63	32	23	20	190	16	21	336
W0950802006	80	36	28	20	194	16	21	572
W0951002006	100	41	30	25	262	20	25	840

Note: Supplied with 4 screws, 4 washers.

N.B.: for fixing the rear head is necessary to use:

- Ø50-63 n. 4 screws M8x40 UNI 5931 (see kit 0950636092)
- Ø80 n. 4 screws M10x40 UNI 5931
- Ø100 n. 4 screws M10x60 UNI 5931 (see kit 0951006092)

CETOP HINGE FOR MODEL B - MODEL GL

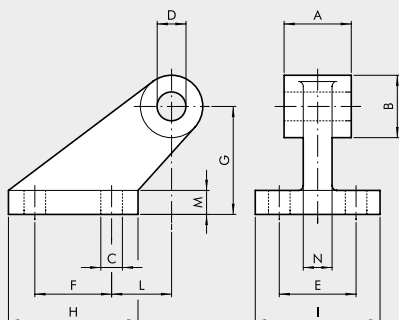

Code	Ø	A	B	C	D	E	F	G	H	I	L	M	N	Weight [g]
W0950502008	50	32	26	9	12	32	32	45	54	52	25	10	12	212
W0950632008	63	40	33	11	16	40	50	63	75	63	32	12	15	440
W0950802008	80	50	33	11	16	40	50	63	75	63	32	12	15	464
W0951002008	100	60	44	14	20	50	70	90	103	80	40	16	22	985

Note: Supplied with 4 screws, 4 washers.

ISO HINGE FOR MODEL B - MODEL GS

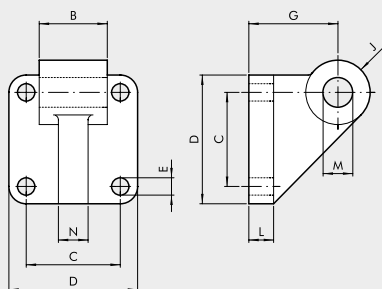

Code	Ø	B	C	D	E	G	J	L	M	N	Weight [g]
W0950502108	50	32	46.5	65	9	45	13	12	12	12	252
W0950632108	63	40	56.5	75	9	50	17	12	16	15	350
W0950802108	80	50	72	95	11	63	17	16	16	15	655
W0951002108	100	60	89	115	11	73	21	16	20	22	980

Note: Supplied with 4 screws, 4 washers.

ISO 15552 HINGE FOR MODEL B - MODEL AB7

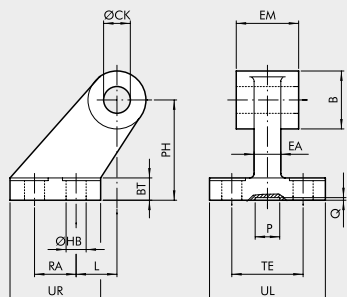

Code	Ø	EM	B	ØHB	ØCK	TE	RA	PH	UR	UL	L	BT	EA	P	Q	Weight [g]
W0950502017	50	32	26	9	12	50	30	45	45	65	3	12	16	21	3	162
W0950632017	63	40	30	9	16	52	35	50	50	67	2	14*	16	21	3	191
W0950802017	80	50	30	11	16	66	40	63	60	86	7	14	20	21	3	332
W0951002017	100	60	38	11	20	76	50	71	70	96	5	17*	20	11	3	522

* Dimensions not to ISO 15552

FRONT FLANGE - MODEL C

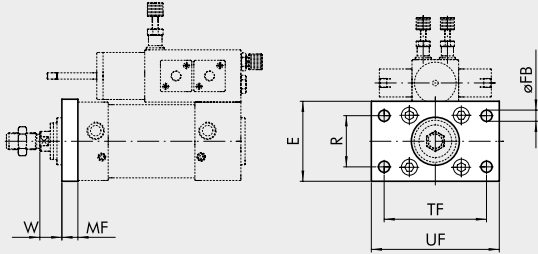

Code	Ø	TF	UF	E	MF	R	øFB	W	Weight [g]
W0950502002	50	90	110	65	12	45	9	20	522
W0950632002	63	100	120	75	12	50	9	25	670
W0950802002	80	126	150	95	15	63	12	17	1420

Note: Supplied with 4 screws.

REAR FLANGE - MODEL C

+ = ADD THE STROKE

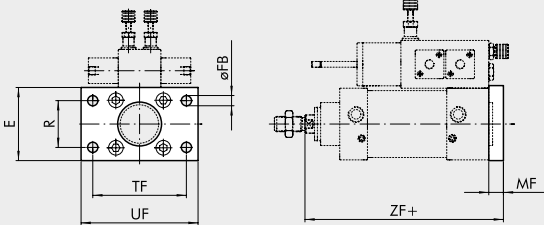

Code	Ø	TF	UF	E	MF	R	øFB	ZF	Weight [g]
W0950502002	50	90	110	65	12	45	9	170	522
W0950632002	63	100	120	75	12	50	9	170	670
W0950802002	80	126	150	95	15	63	12	176	1420
W0951002002	100	150	178	115	16	75	14	205	2040

Note: Supplied with 4 screws.

N.B.: for fixing the rear head is necessary to use:

- Ø50-63 n. 4 screws M8x40 UNI 5931 (see kit 0950636092)
- Ø80 n. 4 screws M10x40 UNI 5931
- Ø100 n. 4 screws M10x60 UNI 5931 (see kit 0951006092)

ROD NUT - MODEL S

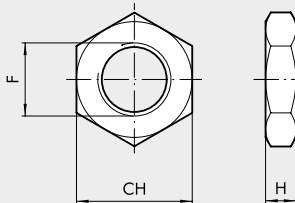

Code	Ø	F	H	CH	Weight [g]
0950502010	50-80	M16x1.5	8	24	20
0950802010	100	M20x1.5	9	30	32

Note: Individually packed.

FORK MODEL GK-M

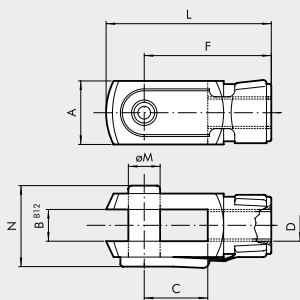

Code	Ø	Ø M	C	B	A	L	F	D	N	Weight [g]
W0950502020	50-80	16	32	16	32	83	64	M16x1.5	40	340
W0950802020	100	20	40	20	40	105	80	M20x1.5	40	690

Note: Individually packed.

ROD EYE - MODEL GA-M

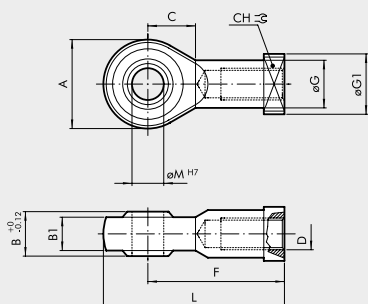

Code	Ø	Ø M	C	B1	B	A	L	F	D	Ø G	CH	Ø G1	Weight [g]
W0950502025	50-80	16	22	15	21	42	85	64	M16x1.5	22	22	22	226
W0950802025	100	20	26	18	25	50	102	77	M20x1.5	27.5	30	27	404

Note: Individually packed.

SELF ALIGNING ROD COUPLER - MODEL GA-K

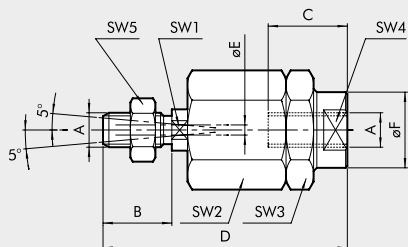

Code	Ø	A	B	C	D	ØF	ØE	SW ₁	SW ₂	SW ₃	SW ₄	SW ₅	Weight [g]
W0950502030	50-80	M16x1.5	32	32	103	32	4	20	41	41	30	24	620
W0950802030	100	M20x1.5	40	40	119	32	4	20	41	41	30	30	680

Note: Individually packed.

KIT OF REAR HEAD SCREWS Ø50-63-100

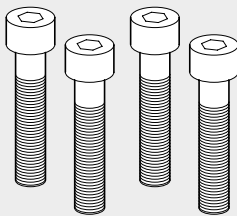

Code	Ø	Description
0950636092	50-63	Kit of M8x40 UNI 5931 rear head fixing screws
0951006092	100	Kit of M10x60 UNI 5931 rear head fixing screws

Note: 4 items per pack.

CYLINDER BRACKET - VALVE SERIES KCV

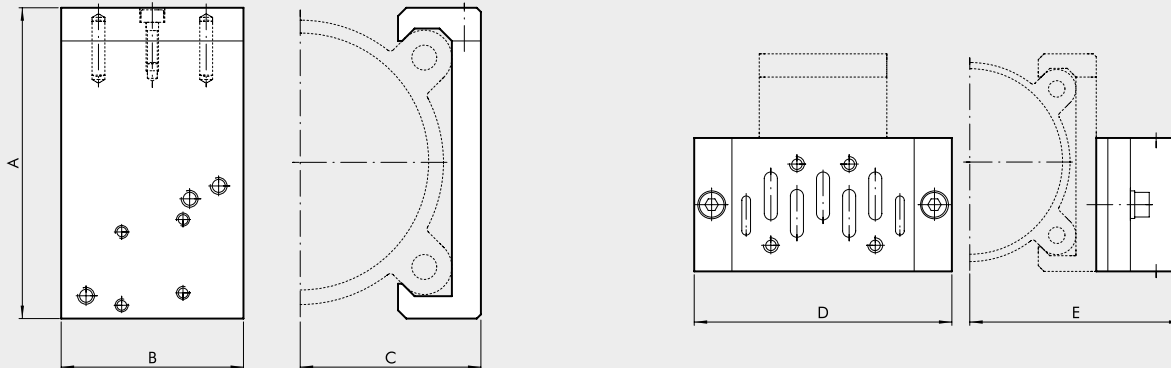

Code	Ø	A	B	C	ISO 1		ISO 2		Applicable valves	Weight [g]
					D	E	D	E		
0950002090	50	71.5	40	37	110	72	124	78	MACH 16 Series 70 1/8-1/4 ISO 1 - ISO 2	93
0950632090	63	81.5	40	42	110	77	124	83	MACH 16 Series 70 1/8-1/4 ISO 1 - ISO 2	101
0950802090	80	99	60	53.5	110	88.5	124	94.5	Series 70 1/8-1/4-1/2 ISO 1 - ISO 2	222
0951002090	100	119.5	60	63.5	110	98.5	124	104.5	Series 70 1/8-1/4-1/2 ISO 1 - ISO 2	258

KIT FOR FIXING VALVES TO BRACKETS

Code	Valve KIT	Composition	Weight [g]
0950002003	MACH 16	2 hex. screws M3x25 with washer	4
0950002004	Series 70 1/8-1/4	2 hex. screws M4x30 with washer	8
0950002001	ISO 1	Adaptor + ISO 1 BASE SIDE + screws + washers (Fig.B)	230
0950002002	ISO 2	Adaptor + ISO 2 BASE SIDE + screws + washers (Fig.B)	350

VALVE ASSEMBLY ON HYDRAULIC BRAKE

FOR Ø 50-63

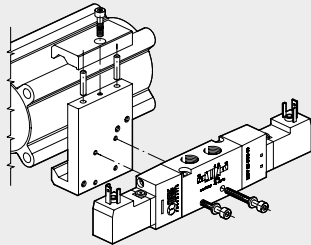

FOR Ø 80-100

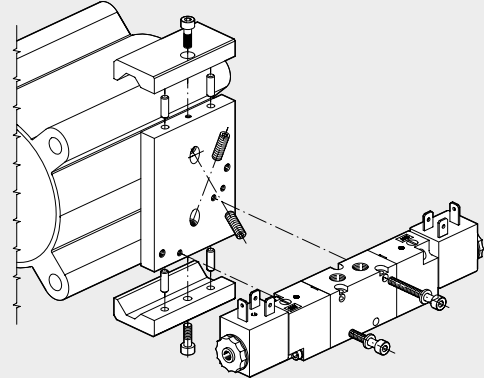

ACCESSORIES: MAGNETIC SENSORS

SENSOR SERIES DSM

For codes and technical data, see **chapter A6**.

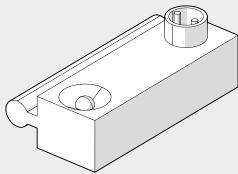

SENSOR SUPPORT BRACKETS FOR SENSORS DSM

Ø 50-63

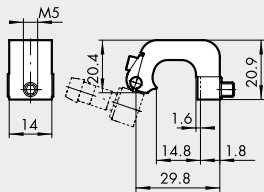

Code	Description
W0950000712	Bracket D.50-63 DST 81

Ø 80-100

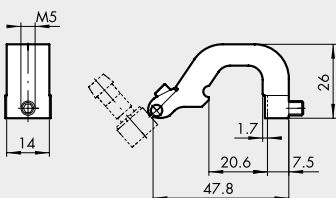

Code	Description
W0950000713	Bracket D.80-100-125 DST 82

RETRACTABLE SENSOR

SENSOR, SQUARE TYPE

Latest generation,
secure fixing

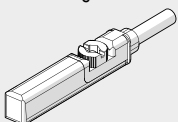

SENSOR, OVAL TYPE

Traditional

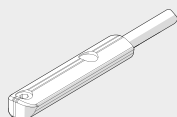

For codes and technical data, see **chapter A6**.

REMOTE REGULATION OF HYDRAULIC BRAKES

ACTUATORS

REMOTE REGULATION OF HYDRAULIC BRAKES

The speed of a BRK series hydraulic brake or an integrated hydraulic brake can be regulated via a precision flow regulator that is physically separated from the brake.

The regulator is connected to the brake via hydraulic hoses.

In this way the regulator can be placed in a position accessible to the operator, for example on a control panel.

The regulator is unidirectional, which means that the speed is regulated in one direction, e.g. at the piston rod extension

The speed in the other direction remains free. You can remote two regulators to control both directions of movement.

This solution is ideal for both the BRK series hydraulic brakes and the integrated hydraulic brakes.



TECHNICAL DATA	
The technical data of the BRK series hydraulic brake or the integrated hydraulic brake with connected remote regulator apply.	
Connection hose length	At the customer's choice. The following lengths are available in a reasonably short delivery time: 500, 1500, 2000, 3000
Minimum hose length	300
Speed regulation	Unidirectional. In case you need to regulate the brake remotely for both extension and retraction, two separate regulators are supplied and the number of hoses required is four.
Number of knob turns, from the closed position to fully open	11

COMPONENTS

- ① HYDRAULIC BRAKE: series BRK or INTEGRATED
- ② REGULATOR: precision, unidirectional
- ③ PIPE: hydraulic hose R7

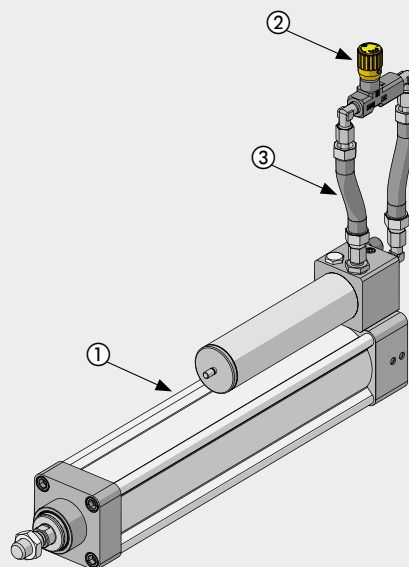

VERSIONS

Remote regulation in extension.
Remote regulation in retraction.

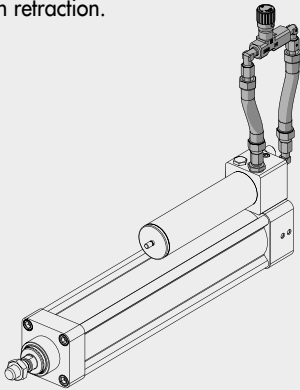

Remote regulation in both piston rod extension and retraction.

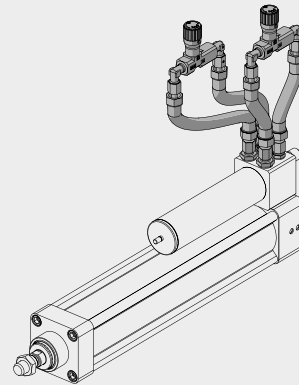

SPEED REGULATION

The speed is reduced by screwing the knob; it increases by unscrewing it.

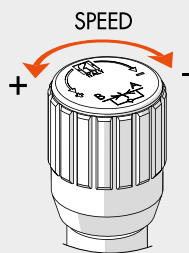

Once the regulation has been made, lock the knob in position by tightening the grub screw at the side.

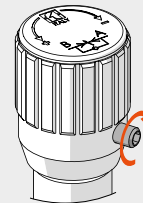

HOW TO ELIMINATE TORSIONAL DEFORMATION OF THE HOSE

The operation must be done in the absence of pressure.

Unscrew the outer fitting by one or two turns.

Let the pipe settle in the most natural position.

Tighten the fitting back on.

This operation applies to the fittings on the regulator side and those on the hydraulic brake side.

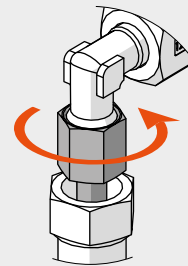

PANEL MOUNTING

The assembly is supplied complete with a separate ring nut. In order to fit the ring nut, you need to remove the regulator knob.

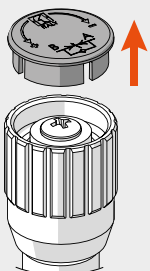

Remove the yellow cover of the knob, with the help of a cutter.

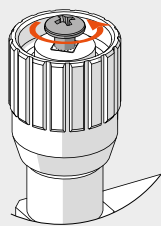

Unscrew the Phillips head screw.

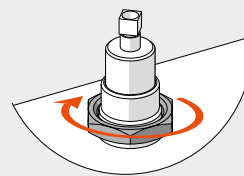

Pull out the knob.

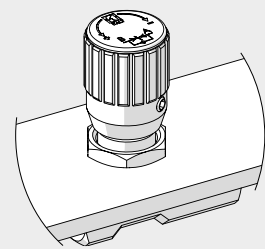

Tighten the ring nuts and reassemble everything.

DIMENSIONS

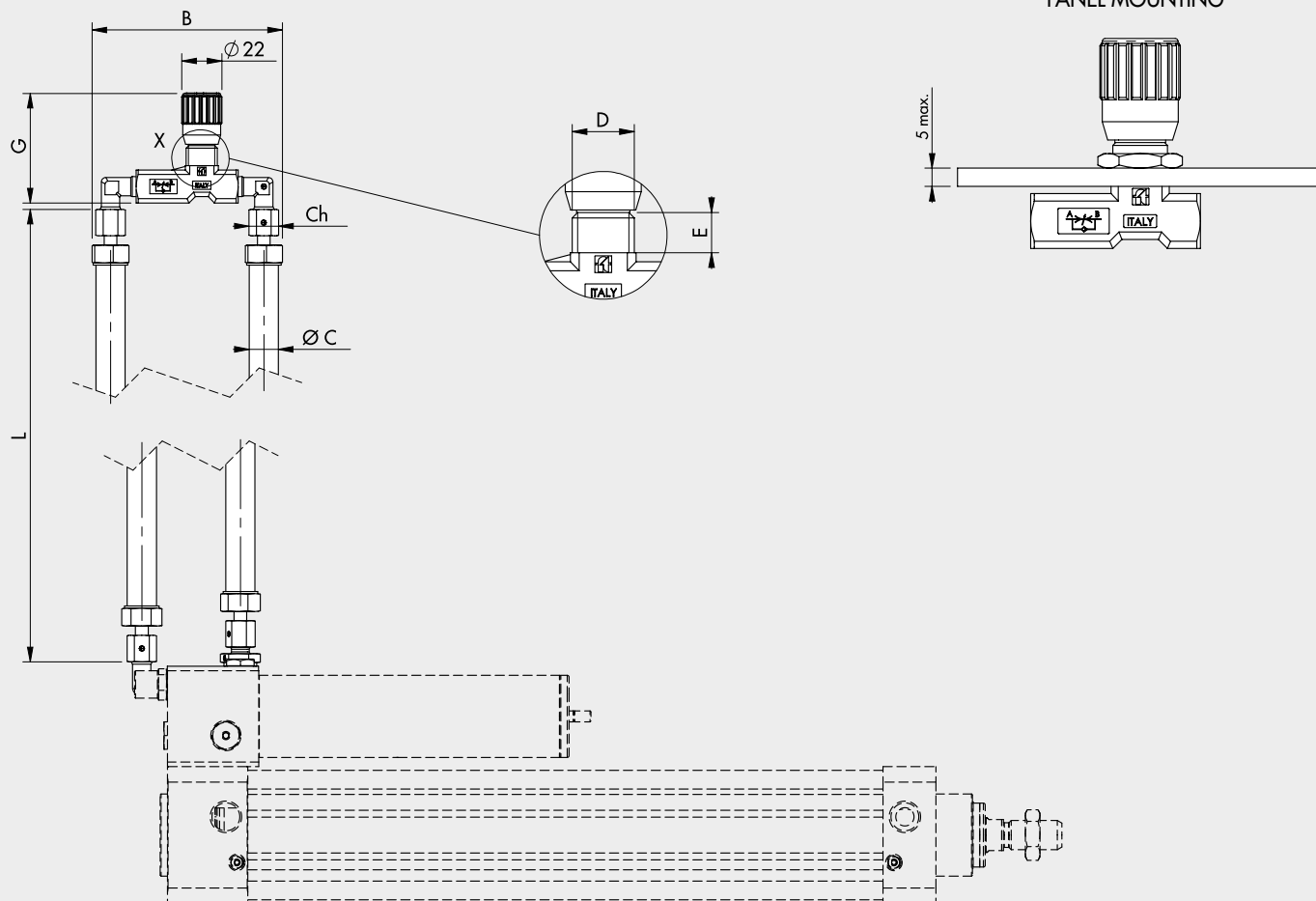

Type of hydraulic brake	B	Ø C	D	E	Ch	G		L	Tube	Minimum radius of the tube
						min	max			
Hydraulic brake series BRK Ø 40, 63	100	12.2	M15x1	12	19	57	61.5	300 to 9999	R7 1/4 pmax 210 bar	35
Cylinder with integrated hydraulic brake Ø 50, 63, 80	85	9.6	M17x1	11	14	55	59	300 to 9999	R7 3/16 pmax 210 bar	25
Cylinder with integrated hydraulic brake Ø 100	100	12.2	M15x1	12	19	57	61.5	300 to 9999	R7 1/4 pmax 210 bar	35

KEY TO CODES

The product code is obtained by adding the type of execution and hose length to the hydraulic brake code

Code Hydraulic brake	R	0 3 0 0
	EXECUTION	PIPE LENGTH
R Remote regulation	Enter the length L [mm] of the hydraulic pipes in 4 digits (example 0500 for length 500)	

Example:

W1700010100R0500 Hydraulic brake series BRK Ø 40, stroke 100 mm, with regulation in extension only. Remote regulation in extension with hose length L = 500 mm
 W173200A0500R2000 Integrated hydraulic brake Ø 50, stroke 500, with regulation in both extension and retraction. Remote regulation in both extension and retraction with hose length L = 2000 mm